

SICOFI[®]2-TE
Two Channel Codec
Filter for Terminal
Application

PSB 2132 Version 2.2

Wired
Communications



Never stop thinking.

Edition 2001-02-20

**Published by Infineon Technologies AG,
St.-Martin-Strasse 53,
D-81541 München, Germany**

**© Infineon Technologies AG 2001.
All Rights Reserved.**

Attention please!

The information herein is given to describe certain components and shall not be considered as warranted characteristics.

Terms of delivery and rights to technical change reserved.

We hereby disclaim any and all warranties, including but not limited to warranties of non-infringement, regarding circuits, descriptions and charts stated herein.

Infineon Technologies is an approved CECC manufacturer.

Information

For further information on technology, delivery terms and conditions and prices please contact your nearest Infineon Technologies Office in Germany or our Infineon Technologies Representatives worldwide (see address list).

Warnings

Due to technical requirements components may contain dangerous substances. For information on the types in question please contact your nearest Infineon Technologies Office.

Infineon Technologies Components may only be used in life-support devices or systems with the express written approval of Infineon Technologies, if a failure of such components can reasonably be expected to cause the failure of that life-support device or system, or to affect the safety or effectiveness of that device or system. Life support devices or systems are intended to be implanted in the human body, or to support and/or maintain and sustain and/or protect human life. If they fail, it is reasonable to assume that the health of the user or other persons may be endangered.

SICOFI[®]2-TE

Two Channel Codec Filter for Terminal Application

PSB 2132 Version 2.2

Wired
Communications



Never stop thinking.

Revision History:**Current Version 2001-02-20**DS 1

Previous Version: Data Sheet 07.97 DS1 (V 1.1)
 Delta Sheet 11.98 DS2 (V 1.4)
 Errata Sheet 05.98 DS1 (V 1.4)

Page	Subjects (major changes since last revision)
------	--

For questions on technology, delivery and prices please contact the Infineon Technologies Offices in Germany or the Infineon Technologies Companies and Representatives worldwide: see our webpage at <http://www.infineon.com/>

ABM[®], AOP[®], ARCOFI[®], ARCOFI[®]-BA, ARCOFI[®]-SP, DigiTape[®], EPIC[®]-1, EPIC[®]-S, ELIC[®], FALC[®]54, FALC[®]56, FALC[®]-E1, FALC[®]-LH, IDEC[®], IOM[®], IOM[®]-1, IOM[®]-2, IPAT[®]-2, ISAC[®]-P, ISAC[®]-S, ISAC[®]-S TE, ISAC[®]-P TE, ITAC[®], IWE[®], MUSAC[®]-A, OCTAT[®]-P, QUAT[®]-S, SICAT[®], SICOFI[®], SICOFI[®]-2, SICOFI[®]-4, SICOFI[®]-4 μ C, SLICOFI[®] are registered trademarks of Infineon Technologies AG.

ACE[™], ASM[™], ASP[™], POTSWIRE[™], QuadFALC[™], SCOUT[™] are trademarks of Infineon Technologies AG.

Table of Contents		Page
	Preface	1
1	Overview	2
1.1	Features	3
1.2	Logic Symbol	4
1.3	Typical Applications	4
2	Pin Descriptions	5
2.1	Pin Diagram	5
2.2	Pin Definitions and Functions	6
3	Functional Description	10
3.1	DSP-based Architecture	10
3.2	Programming and Control	10
4	Operational Description	12
4.1	Operating States	12
4.1.1	Power On	12
4.1.2	Hardware Reset	13
4.2	Transmission Characteristics	14
4.2.1	Overload Point	14
4.2.2	0 dBm ₀ -Levels	14
4.2.3	Compressor Gain Relative to Coding Law	15
4.2.4	Operating Conditions	16
4.2.5	Gain Accuracy	17
4.2.6	Gain Tracking (Receive and Transmit)	17
4.2.7	Frequency Response	18
4.2.8	Group Delay	18
4.2.8.1	Group Delay, Absolute Values	18
4.2.8.2	Group Delay Distortion with Frequency	19
4.2.9	Noise	19
4.2.10	Harmonic and Intermodulation Distortion	20
4.2.11	Total Distortion	20
4.2.12	Single Frequency Distortion	21
4.2.13	Overload Compression	21
4.2.14	Crosstalk	21
4.2.15	Out-of-Band Discrimination in Transmit Direction	22
4.2.16	Out-of-Band Discrimination in Receive Direction	23
4.2.17	Out-of-Band Idle Channel Noise at Analog Output	23
4.2.18	Transhybrid Loss	24
5	Interface Description	25
5.1	Analog Interface	25
5.1.1	Coupling Capacitors at the Analog Interface	25

Table of Contents		Page
5.1.2	Analog Interface Pins	27
5.2	IOM-2 PCM Interface	27
5.2.1	IOM-2 PCM Interface Pins	28
5.2.2	IOM-2 PCM Time Slot Configuration in TE Mode	28
5.3	Signaling Interface	29
5.3.1	Signaling Interface Pins	30
5.3.2	Debouncing Functions and Interrupt Generation	31
5.3.3	Clock Output Signals	31
5.4	Serial Microcontroller Interface	31
5.4.1	Serial Microcontroller Interface Pins	32
5.4.2	Write Access	32
5.4.3	Read Access	33
5.4.4	Three-Wire Access	34
6	Programming Overview	35
6.1	Programming Overview	35
6.1.1	Register Model	35
6.1.2	Register Maps	36
6.1.3	CRAM Structure	37
6.2	Types of Commands and Data Bytes	38
7	Application Hints	39
7.1	Support Tools	39
7.1.1	Development Board	39
7.2	Guidelines for Board Design	40
7.2.1	Filter Capacitors	40
7.3	Proposal for SICOFI [®] 2-TE Board Design	41
8	Electrical Characteristics and Timing Diagrams	42
8.1	Absolute Maximum Ratings	42
8.2	Operating Range	43
8.3	Digital Interface	43
8.4.1	Coupling Capacitors at the Analog Interface	44
8.5	Reset Timing	44
8.4	Analog Interface	44
8.6	IOM-2 PCM-Interface Timing	45
8.6.1	Single Clocking Mode	45
8.6.2	Double Clocking Mode	46
8.7	Microcontroller Interface Timing	47
8.8	Signaling Interface Timing	48
8.8.1	Timing from the Microcontroller Interface to the SO/SB-pins	48
8.8.2	Timing from the SI/SB-pins to the Microcontroller Interface	48

Table of Contents		Page
9	Test Modes	49
9.1	Analog Loops	49
9.2	Digital Loops	50
9.3	Cut-Off's	51
10	Package Outlines	52
11	Glossary	53
	Index	54

List of Figures		Page
Figure 1	SICOFI [®] 2-TE Architecture	2
Figure 2	SICOFI [®] 2-TE Logic Symbol	4
Figure 3	Pin Configuration of SICOFI [®] 2-TE	5
Figure 4	SICOFI [®] 2-TE Block Diagram	11
Figure 5	SICOFI [®] 2-TE State Diagram	12
Figure 6	Analog and PCM Signal Levels in A-Law Mode	15
Figure 7	Analog and PCM Signal Levels in μ -Law Mode	15
Figure 8	Simplified Signal Flow Diagram	16
Figure 9	Total Distortion Measured with Sine-Wave, Receive and Transmit	20
Figure 10	Overload Compression (μ -Law Coding, Transmit Direction)	21
Figure 11	Out-of-Band Discrimination in Transmit Direction	22
Figure 12	Analog Output: Out-of-Band Signals	23
Figure 13	Analog Output: Out-of-Band Idle Channel Noise	24
Figure 14	Analog Interface to Two Subscriber Line Interface Circuits (SLICs)	26
Figure 15	IOM-2 PCM Interface Time Slot Positions	29
Figure 16	Signaling Example: Two Subscriber Lines	30
Figure 17	Serial Microcontroller Interface	32
Figure 18	Example for a Two-Byte Write Access	33
Figure 19	Example for a One-Byte Read Access	33
Figure 20	Example for a Read Access with Byte-by-Byte Transfer	34
Figure 21	Bi-Directional Data Signal: DIN and DOUT Strapped Together	34
Figure 22	Channel-Specific and Common Coefficients	37
Figure 23	Development System with STUT 2466 Evaluation Board	39
Figure 24	SICOFI [®] 2-TE Test Circuit Configuration	40
Figure 25	Proposal for a Ground Concept	41
Figure 26	PCM Interface Timing in Single Clocking Mode	45
Figure 27	PCM Interface Timing in Double Clocking Mode	46
Figure 28	Timing of the Microcontroller Interface	47
Figure 29	Signaling Output Timing (Data Downstream)	48
Figure 30	Analog Loops	49
Figure 31	Digital Loops	50
Figure 32	Cut-Off's	51

List of Tables	Page
Table 1	Pin Definitions and Functions 6
Table 2	Register Values and Accessibility 13
Table 3	Input and Output Pin Behavior. 13
Table 4	Power Dissipation 14
Table 5	Maximum Signal Levels. 14
Table 6	Analog Voltage Levels Corresponding to 0 dBm0-Level 14
Table 7	Gain Accuracy 17
Table 8	Gain Deviations with Input Level 17
Table 9	Attenuation with Frequency in Transmit and Receive Direction. 18
Table 10	Group Delay, Absolute Values. 18
Table 11	Group Delay Distortion with Frequency 19
Table 12	Idle Channel Noise in Transmit Direction. 19
Table 13	Idle Channel Noise in Receive Direction 19
Table 14	Harmonic and Intermodulation Distortion. 20
Table 15	Signal-to-Total Distortion Ratio Measured with Sine Wave 20
Table 16	Single Frequency Distortion. 21
Table 17	Crosstalk Between Channels. 21
Table 18	Out-of-Band Signals Applied to the Analog Inputs (VINx) 22
Table 19	Out-of-Band Signals at the Analog Outputs (VOUTx) 23
Table 20	Transhybrid Loss 24
Table 21	Analog Interface Pins. 27
Table 22	IOM-2 PCM Interface Pins 28
Table 23	IOM-2 Time Slot Selection 28
Table 24	Signaling Interface: Pins and Functions for SLIC Interfaces 30
Table 26	Clock Programming 31
Table 27	Serial Microcontroller Interface: Pins and Functions 32
Table 28	Register Model 35
Table 29	Read Access to Common Configuration Register (XR) Map. 36
Table 30	Write Access to Common Configuration Register (XR) Map 36
Table 31	Channel-Specific Configuration Register (CR) Map (Read & Write) . . 36
Table 32	Coefficient RAM (CRAM) Structure per Channel. 37
Table 33	Coefficient RAM (CRAM) Structure per Set. 38
Table 34	Types of Commands and Data Bytes. 38
Table 35	Analog Loop Programming in Register CR3, Bits 7 to 4 49
Table 36	Digital Loop Programming in Register CR3, Bits 7 to 4. 50
Table 37	Cut-Off Programming in Register CR2, Bits 7 to 5. 51

Preface

This document provides detailed technical information about the SICOFI[®]2-TE. It is intended for anyone considering or using the device for system design or board layout for a broad range of analog telephony applications.

Organization of this Document

This Hardware Reference Manual is organized as follows:

- Chapter 1, Overview
Includes a general description of the architecture, feature list, and logic symbol.
- Chapter 2, Pin Descriptions
Illustrates the Pin Configuration and provides detailed functional descriptions.
- Chapter 3, Functional Description
Provides a block diagram and summarizes the major functional blocks.
- Chapter 4, Operational Description
Begins with a state diagram and description of the operating states of all two channels and concludes with detailed transmission characteristics.
- Chapter 5, Interface Descriptions
Describes the Analog, IOM-2 PCM, Signaling, and Serial Microcontroller interfaces.
- Chapter 6, Programming Overview
Illustrates the register model and coefficient RAM structure, provides a register map and summary, and identifies the programming command sequences.
- Chapter 7, Application Hints
Describes the development system available for the PSB 2132, and provides guidelines and schematics for board layout.
- Chapter 8, Electrical Characteristics and Timing Diagrams
Provides detailed tables for the electrical characteristics and includes timing diagrams for the Analog, IOM-2 PCM, Serial Microcontroller, and Signaling interfaces.
- Chapter 9, Test Configuration
Describes the test loops and cut-offs available for functional tests and diagnostics.
- Chapter 10, Package Outlines
Illustrates the P-MQFP-64 package in which the PSB 2132 is manufactured.
- The Appendix
Includes a glossary and an index.

Related Documentation

Other documentation for the PSB 2132 includes a *Product Brief*, a *Product Overview*, a *Programmer's Reference Manual*, and assorted *Application Notes*. Similar documentation is also available for the other members of the SICOFI Codec family including the PSB 2134, PEB 2466, and PEB 2266. Documentation is available by accessing our website: <http://www.infineon.com/sicofi>

1 Overview

The two-channel codec filter PSB 2132 SICOFI[®]2-TE is built around a central DSP-core which provides independent filter structures for both channels. Its analog I/O pins are used to connect to external subscriber line interface circuits (SLICs). Their signals are internally routed to the analog-to-digital and digital-to-analog converters (ADC, DAC). The signaling pins carry line status and control information to and from the SLICs. Two programmable clock outputs are available, one of which can be used for generating a ringing signal (RGEN). The SICOFI[®]2-TE's IOM-2 PCM Interface connects directly to a 768 kbit/s IOM-2 bus, often used in terminal equipment. The digitized voice band signals are available as A-Law or μ -Law codes within selectable 8-bit time slots.

The SICOFI[®]2-TE modes, features, and filter characteristics are programmed through a serial interface to a microcontroller. The access mechanism is very simple, and can be implemented with as few as three I/O ports.

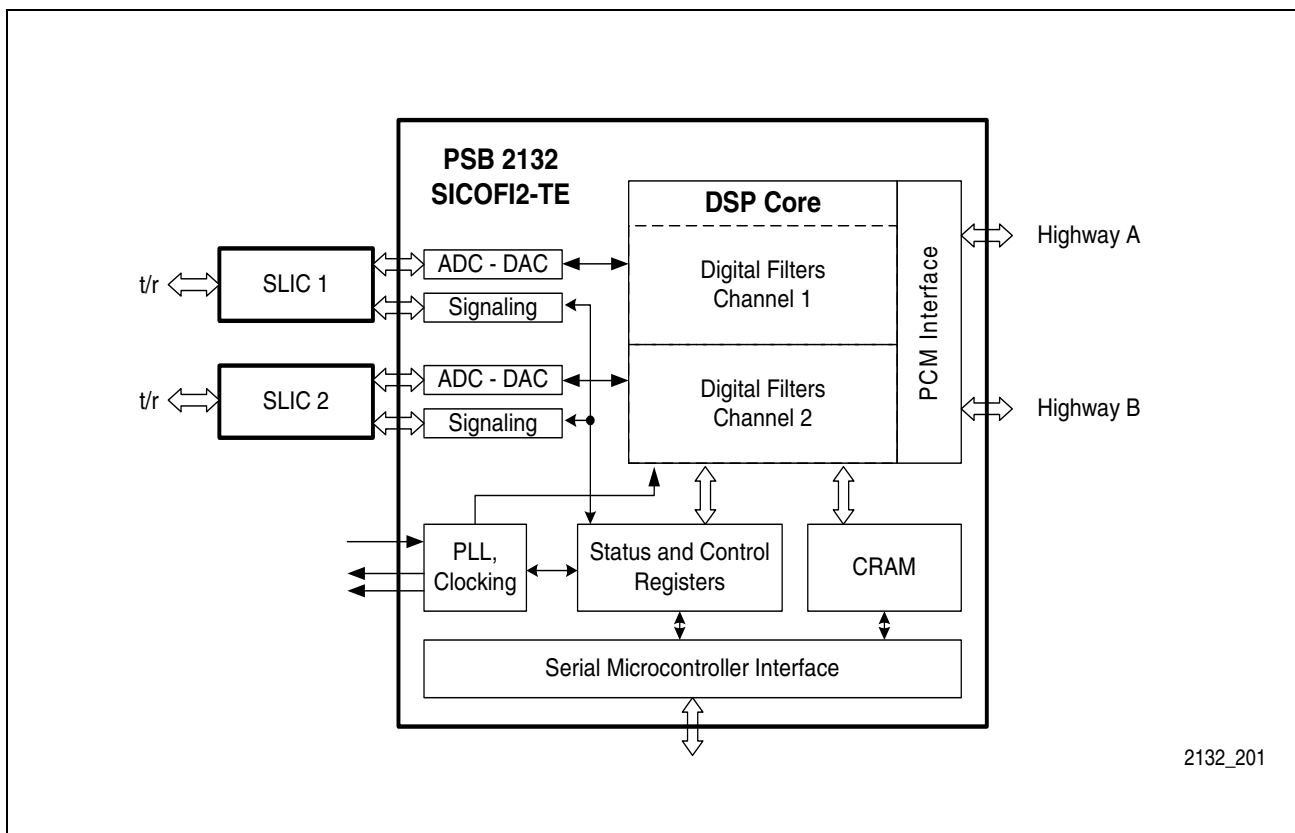

Figure 1 SICOFI[®]2-TE Architecture

Version 2.2

CMOS

1.1 Features

- Two-channel single chip codec with digital filters
- High analog driving capability (300 Ω, 50 pF) for direct driving of transformers
- Digital Signal Processing (DSP) technique
- Programmable digital filters to adapt transmission behavior, especially for:
 - AC impedance matching
 - Transhybrid balancing
 - Frequency response
 - Signal levels
 - A/μ-Law compression and expansion
- Fulfills international (e.g. ITU-T Q.552, G.712) and country-specific requirements
- High performance ADC and DAC for excellent linearity and dynamic gain
- Programmable Analog Interface to electronic SLICs or transformer solutions
- Seven SLIC-signaling I/O pins per channel with programmable debouncing
- IOM-2 compatible PCM interface (1.536 MHz DCL, 768 kHz Bit Clock)
- Easy to use 4-pin Serial Microcontroller Interface (SPI compatible) for read/write access
- Single supply voltage (5 V)
- Advanced low-power mixed-signal CMOS technology
- Two programmable tone generators per channel (DTMF possible)
- Level metering function for system tests and for analog input signal testing
- Advanced on-chip functions for device and system diagnostics and manufacturing test
 - Five digital loops
 - Four analog loops
- Support tools include:
 - Hardware development board — STUT 2466
 - QSICOS Coefficient Calculation and Register Configuration Software
- Standard P-MQFP-64 package

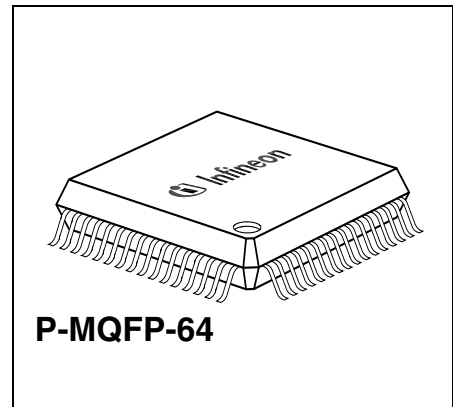

Type	Package
PSB 2132 Version 2.2	P-MQFP-64

1.2 Logic Symbol

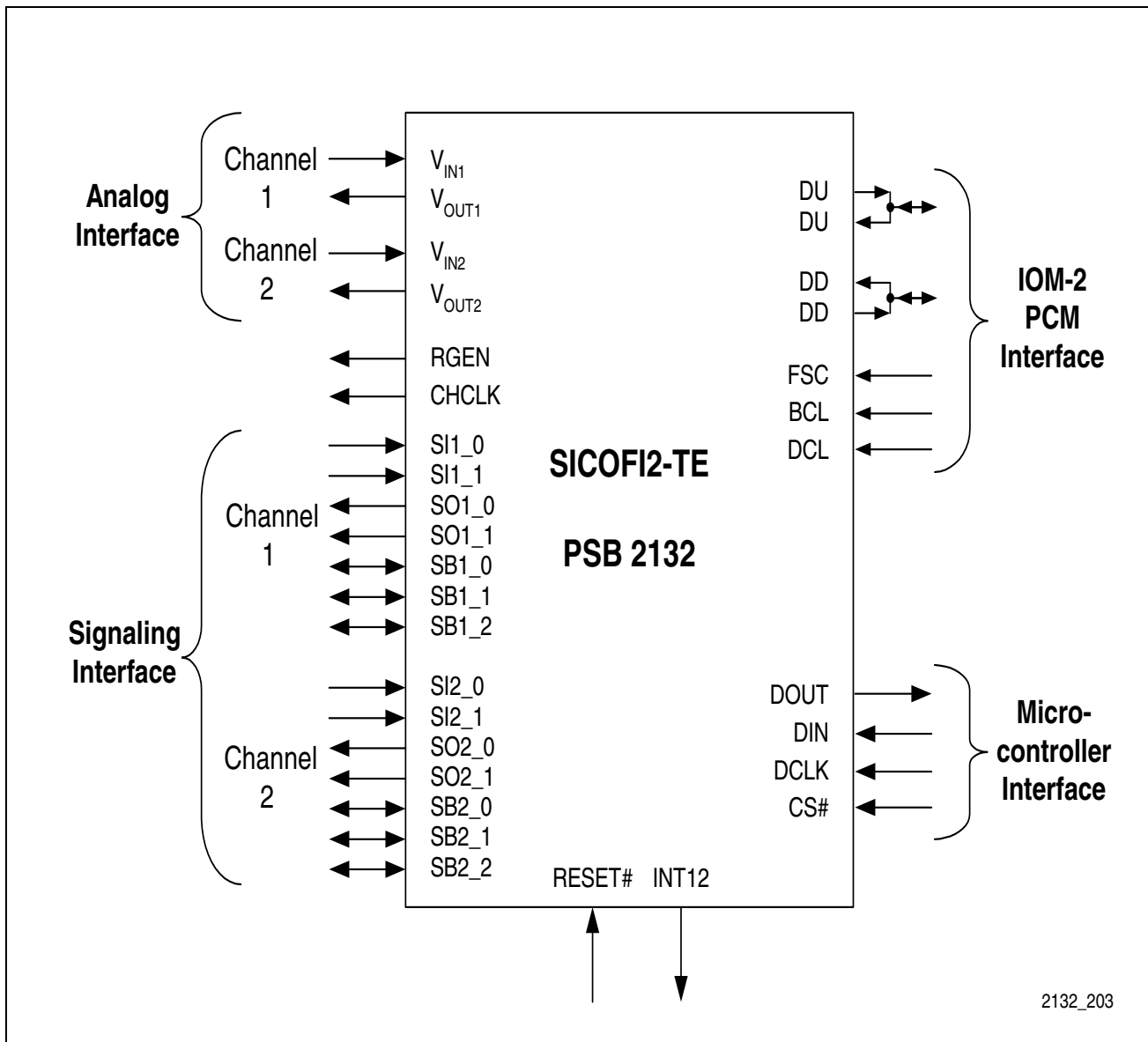

Figure 2 SICOFI[®]2-TE Logic Symbol

1.3 Typical Applications

Many applications will benefit from the versatility of the SICOFI[®]2-TE codec and filter. The inherent flexibility enables several products to be developed around one basic architecture, thus affording potentially significant savings in time to market, inventory costs, and support administration.

The following list represents some of the typical applications for which the SICOFI[®]2-TE codec was designed: Small PBX, Terminal Adapters, and intelligent NTs. Refer to the **Product Overview, Chapter 5 Application Hints** for more information.

2 Pin Descriptions

2.1 Pin Diagram

(top view)

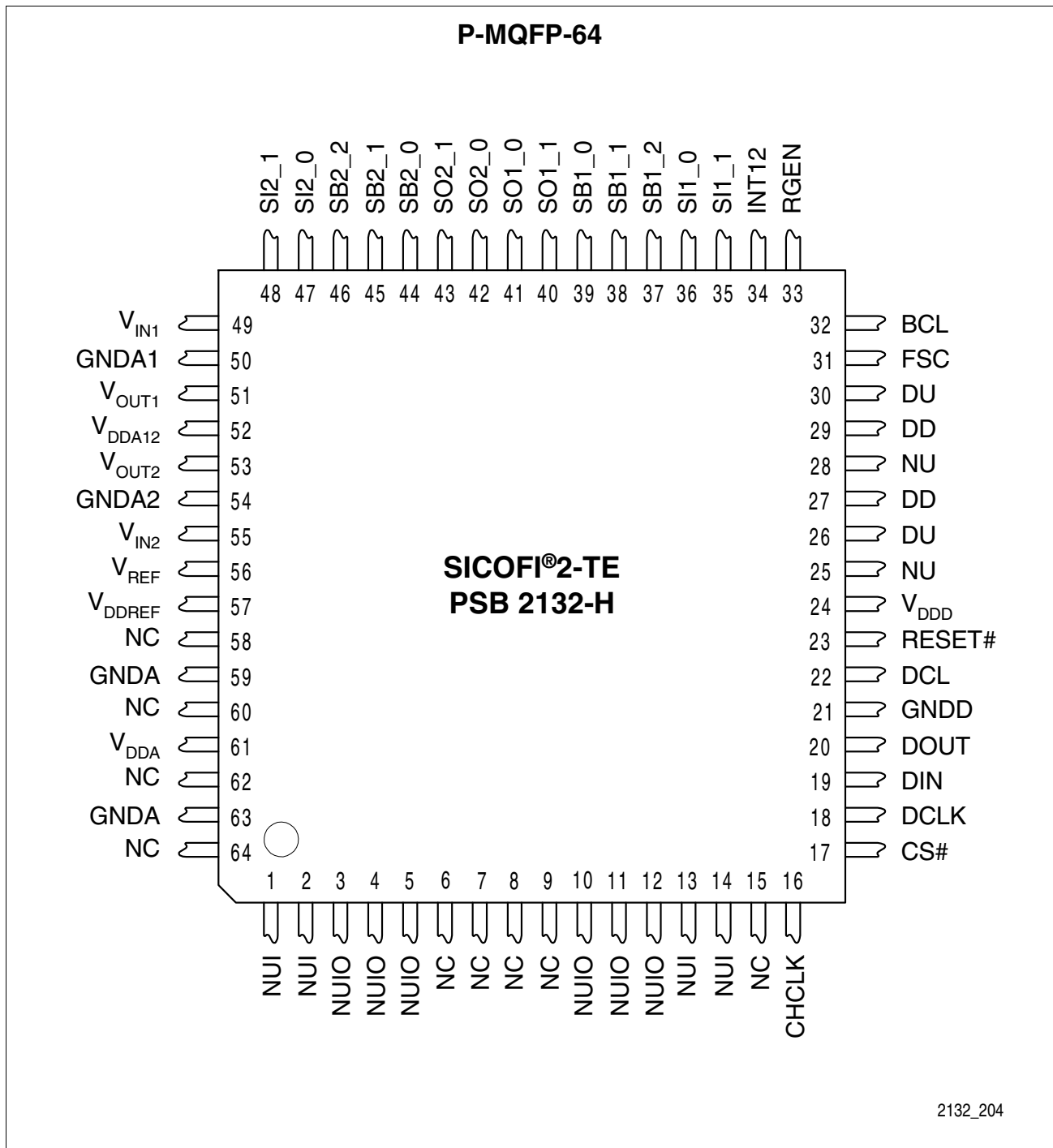

Figure 3 Pin Configuration of SICOFI®2-TE

2.2 Pin Definitions and Functions

Table 1 Pin Definitions and Functions

Pin	Symbol	Type	Function	Ch.
1, 2	NUI	I	Non Usable Input Pins must be tied directly to digital ground GNDD (Pin 21)	
3, 4, 5	NUIO	I/O	Non Usable Input/Output Pins must be tied via a pull-down-resistor to digital ground GNDD (Pin 21)	
6, 7, 8, 9	NC		Not Connected Pins are not connected in this device.	
10, 11, 12	NUIO	I/O	Non Usable Input/Output Pins must be tied via a pull-down resistor to digital ground GNDD (Pin 21)	
13, 14	NUI	I	Non Usable Input Pins must be tied directly to digital ground GNDD (Pin 21)	
15	NC		Not Connected Pin is not connected in this device.	
16	CHCLK	O	Chopper Clock Output Provides 256, 512, or 16,384 kHz signal; sync. to DCL.	both
17	CS#	I	Chip Select Microcontroller Interface Chip Select, enable to read or write; active low.	both
18	DCLK	I	Data Clock Microcontroller Interface data clock, shifts data from or to device; maximum clock rate 8192 kHz.	both
19	DIN	I	Data Input Microcontroller Interface control data input pin; DCLK determines data rate.	both
20	DOUT	O	Data Output Microcontroller Interface control data output pin; DCLK determines data rate: DOUT is high impedance "Z" if no data is transmitted from the SICOFI [®] 2-TE.	both
21	GNDD	I	Digital Ground Ground reference for all digital signals. Internally isolated from GNDA1 (Pin 50), GNDA2 (Pin 54), and GNDA (Pins 59 and 63).	both

Pin Descriptions

Pin	Symbol	Type	Function	Ch.
22	DCL	I	Master Clock Input 1536 kHz signal must be applied for any operation. DCL, BCL, and FSC must be synchronous.	both
23	RESET#	I	Reset Input Forces the device to default setting mode; active low.	both
24	V _{DDD}	I	Digital Supply Voltage +5 V supply for digital circuits (use 100 nF blocking cap.).	both
25	NU		None Usable Leave unconnected.	
26	DU	I/O/ tri- state	IOM-2 Data Upstream Interface together with Pin 30. Both pins must be connected together. Transmits or receives PCM data in 8-bit bursts every 125 μ s. With push-pull resistor.	both
27	DD	I/O/ tri- state	IOM-2 Data Downstream Interface together with Pin 29. Both pins must be connected together. Transmits or receives PCM data in 8-bit bursts every 125 μ s. With push-pull resistor.	both
28	NU		None Usable Leave unconnected.	
29	DD	I/O/ tri- state	IOM-2 Data Downstream Interface together with Pin 27. Both pins must be connected together. Transmits or receives PCM data in 8-bit bursts every 125 μ s. With push-pull resistor.	both
30	DU	I/O/ tri- state	IOM-2 Data Upstream Interface together with Pin 26. Both pins must be connected together. Transmits or receives PCM data in 8-bit bursts every 125 μ s. With push-pull resistor.	both
31	FSC	I	Frame Synchronization Clock 8 kHz; reference for individual time slots, indicates start of PCM frame; DCL, BCL and FSC must be synchronous.	both
32	BCL	I	IOM-2 Bit Clock Determines rate at which PCM data is shifted into or out of PCM-ports. BCL, DCL, and FSC must be synchronous. If C-MODE = 0 in XR6, single clocking mode is used; 768 kHz must be applied to BCL. If C-MODE = 1 in XR6, double clocking mode is used; 1536 kHz must be applied to BCL. The data rate at the PCM ports remains 768 kbit/s.	both

Pin Descriptions

Pin	Symbol	Type	Function	Ch.
33	RGEN	O	Ring Generator Output Configurable output clock (2 ... 28 ms) synchronous to DCL. Square-wave signal with duty cycle 1:1.	both
34	INT12	O	Interrupt Output, Channels 1 and 2 Active high.	both
35	SI1_1	I	Signaling Input Channel 1, Pin 1	1
36	SI1_0	I	Signaling Input Channel 1, Pin 0	1
37	SB1_2	I/O	Bi-directional Signaling, Channel 1 Pin 2	1
38	SB1_1	I/O	Bi-directional Signaling, Channel 1 Pin 1	1
39	SB1_0	I/O	Bi-directional Signaling, Channel 1 Pin 0	1
40	SO1_1	O	Signaling Output, Channel 1, Pin 1	1
41	SO1_0	O	Signaling Output, Channel 1, Pin 0	1
42	SO2_0	O	Signaling Output, Channel 2, Pin 0	2
43	SO2_1	O	Signaling Output, Channel 2, Pin 1	2
44	SB2_0	I/O	Bi-directional Signaling, Channel 2 Pin 0	2
45	SB2_1	I/O	Bi-directional Signaling, Channel 2 Pin 1	2
46	SB2_2	I/O	Bi-directional Signaling, Channel 2 Pin 2	2
47	SI2_0	I	Signaling Input, Channel 2, Pin 0	2
48	SI2_1	I	Signaling Input, Channel 2, Pin 1	2
49	V_{IN1}	I	Analog Voice (Voltage) Input, Channel 1 Requires a coupling capacitor >39 nF to the SLIC.	1
50	GNDA1	I	Analog Ground, Channel 1 Not internally connected to GNDD or GNDA2 or GNDA.	1
51	V_{OUT1}	O	Analog Voice (Voltage) Output, Channel 1 Requires a coupling capacitor to the SLIC. The capacitor value depends on the SLIC's input impedance. (See Chapter 5.1 , "Analog Interface" on page 25).	1
52	V_{DDA12}	I	Analog Supply Voltage, Channels 1 and 2 +5 V (100 nF blocking capacitor required).	both
53	V_{OUT2}	O	Analog Voice (Voltage) Output, Channel 2 Requires a coupling capacitor to the SLIC. The capacitor value depends on the SLIC's input impedance. (See Chapter 5.1 , "Analog Interface" on page 25).	2

Pin Descriptions

Pin	Symbol	Type	Function	Ch.
54	GNDA2	I	Analog Ground, Channel 2 Not internally connected to GNDD or GNDA1 or GNDA.	2
55	V_{IN2}	I	Analog Voice (Voltage) Input, Channel 2 Requires a coupling capacitor >39 nF to the SLIC.	2
56	V_{REF}	I/O	Reference Voltage Must connect to a 220 nF cap. to ground.	both
57	V_{DDREF}	I	Analog Supply Reference Voltage +5 V (100 nF blocking capacitor required).	both
58	NC		Not Connected Pin is not connected in this device.	
59	GNDA	I	Analog Ground Internally isolated from GNDD (Pin 21), GNDA1(Pin 50), and GNDA2 (Pin 54).	
60	NC		Not Connected Pin is not connected in this device.	
61	V_{DDA}	I	Analog Supply Voltage +5 V (100 nF blocking capacitor required).	
62	NC		Not Connected Pin not connected in this device.	
63	GNDA	I	Analog Ground Internally isolated from GNDD (Pin 21), GNDA1(Pin 50), and GNDA2 (Pin 54).	
64	NC		Not Connected Pin is not connected in this device.	

3 Functional Description

The SICOFI[®]2-TE in combination with four Subscriber Line Interface Circuits (SLIC) provides four analog telephone lines. The SLIC can be either a transformer or an electronic circuit with operational amplifiers. It must have a defined input impedance towards the analog line for maximum power transfer and return loss. Also, the signal reflections that are generated by the hybrid inside the SLIC must be eliminated. Along with its other features, the SICOFI[®]2-TE has built-in impedance matching and transhybrid balancing to perform these tasks.

3.1 DSP-based Architecture

The impedance matching and transhybrid balancing functions are performed by loop filters between the transmit path (analog to PCM) and the receive path (PCM to analog). The filter characteristics must be adjusted according to the local requirements of each market. In the analog domain, filters must be optimized in hardware; this is generally both tedious and time-consuming. This is not the case with the DSP-based SICOFI[®]2-TE two-channel codec. Its integrated signal processor implements the impedance matching and transhybrid balancing functions as digital, programmable filters. It also performs frequency response corrections and level adjustments to enable the design of a truly universal and internationally applicable telephone interface. Transmission characteristics and frequency behavior are enhanced by the accuracy of the digital filters, which do not fluctuate over temperature or with age.

As an additional benefit of its DSP-based architecture, the PSB 2132 also provides two tone generators per channel. An on-chip level-metering unit allows line-characterization without extra hardware; it can also be used to detect specific tones, e.g., modem tones.

3.2 Programming and Control

A very simple Microcontroller Interface is used to program the SICOFI[®]2-TE functions. The same port provides access to 14 general purpose I/O pins of the Signaling Interface. This allows efficient and convenient monitoring and control of other tip/ring functions, such as on-/off-hook detection, ground-key detection, switching of ring signals and test relays. The Serial Microcontroller Interface provides a programming and control interface and is generic and non-proprietary for use with any microcontroller. It can be implemented with as few as three signal lines, since the data receive and data transmit pins may be strapped together.

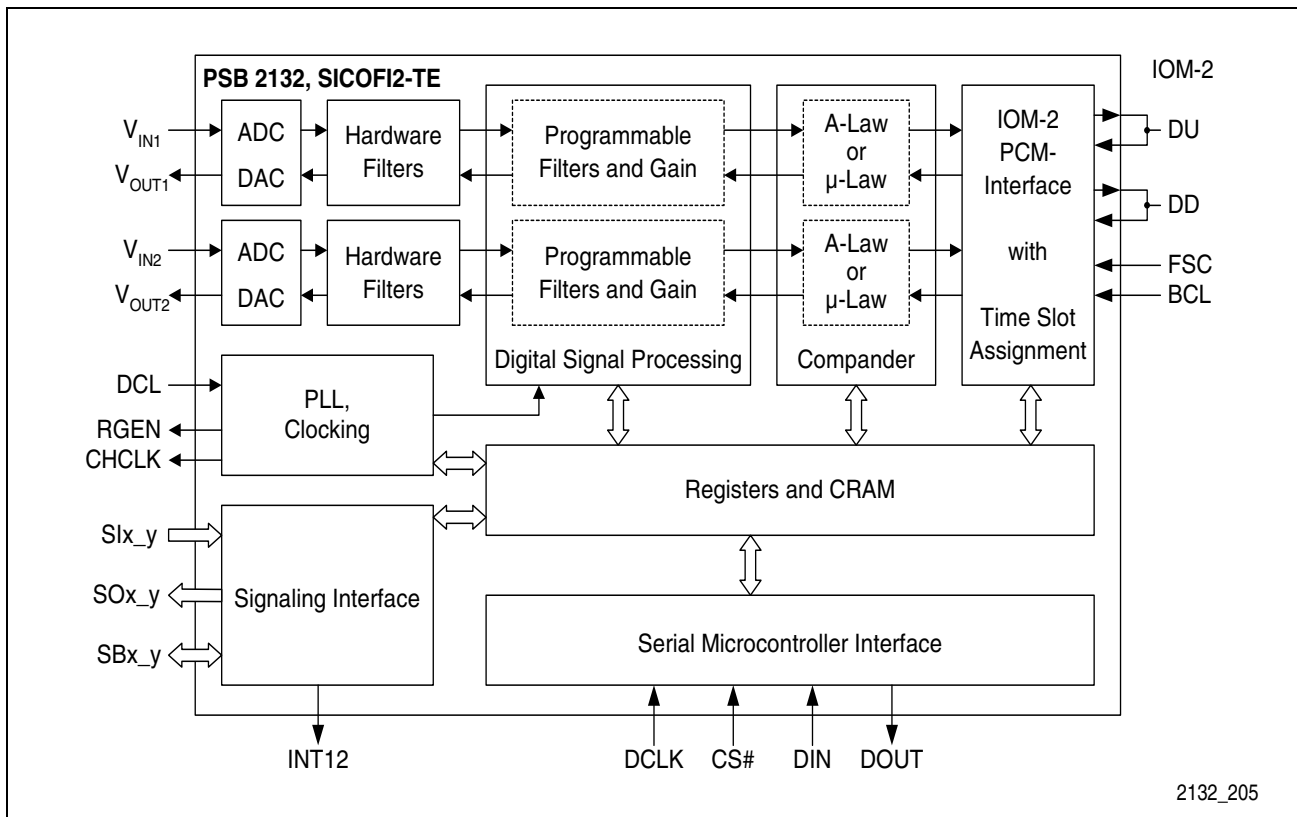

Figure 4 SICOFI[®]2-TE Block Diagram

Figure 4 shows the functional blocks and the interface pins of the SICOFI[®]2-TE:

- Two independent bi-directional voice channels;
- Oversampling sigma-delta A/D and D/A converters with excellent resolution, dynamic range, linearity, accuracy and signal-to-noise performance;
- Hardware filters for decimation and interpolation of the ADC and DAC bit stream, and pre-processing of the voice data to reduce the load of the DSP;
- DSP core with programmable, channel-independent filter structures for impedance matching, transhybrid balancing, frequency correction and level adjustments;
- Configurable A-Law or μ -Law compressor and expander units;
- An IOM-2 PCM interface with time slot assignment, one input and one output connected to DU, and one input and one output connected to DD;
- Three clock inputs, DCL, BCL, and FSC also apply to the IOM-2 PCM Interface;
- 14 signaling input and output pins, accessible through registers;
- Two interrupt outputs, one for each channel-pair 1&2, and 3&4;
- One interrupt output;
- On-chip PLL for an internal 16,384 kHz clock;
- Eight common configuration registers (XR-Registers) affecting both channels;
- Two sets of six channel-specific registers (CR-Registers);
- Coefficient RAM (CRAM) for filter coefficients storage for each channel;
- The Serial Microcontroller Interface has four signals: DIN, DOUT, DCLK, and CS#.

4 Operational Description

Each channel of the SICOFI[®]2-TE can be in one of two stable states: “Standby” and “Operating”. These states can be switched by programming Bit 0 (PU) in the channel-specific configuration register CR1. “Standby” is a power-saving state. Keeping any unused channels in this state reduces the overall system power dissipation. The third state, “Reset”, is transient and is reached after applying power to the device (Power On), after asserting a logic low signal to the RESET#-pin (HW-Reset), or after issuing an XOP command with Bit 7 (RST) set to “1” (SW-Reset). Both channels would be affected in any case.

4.1 Operating States

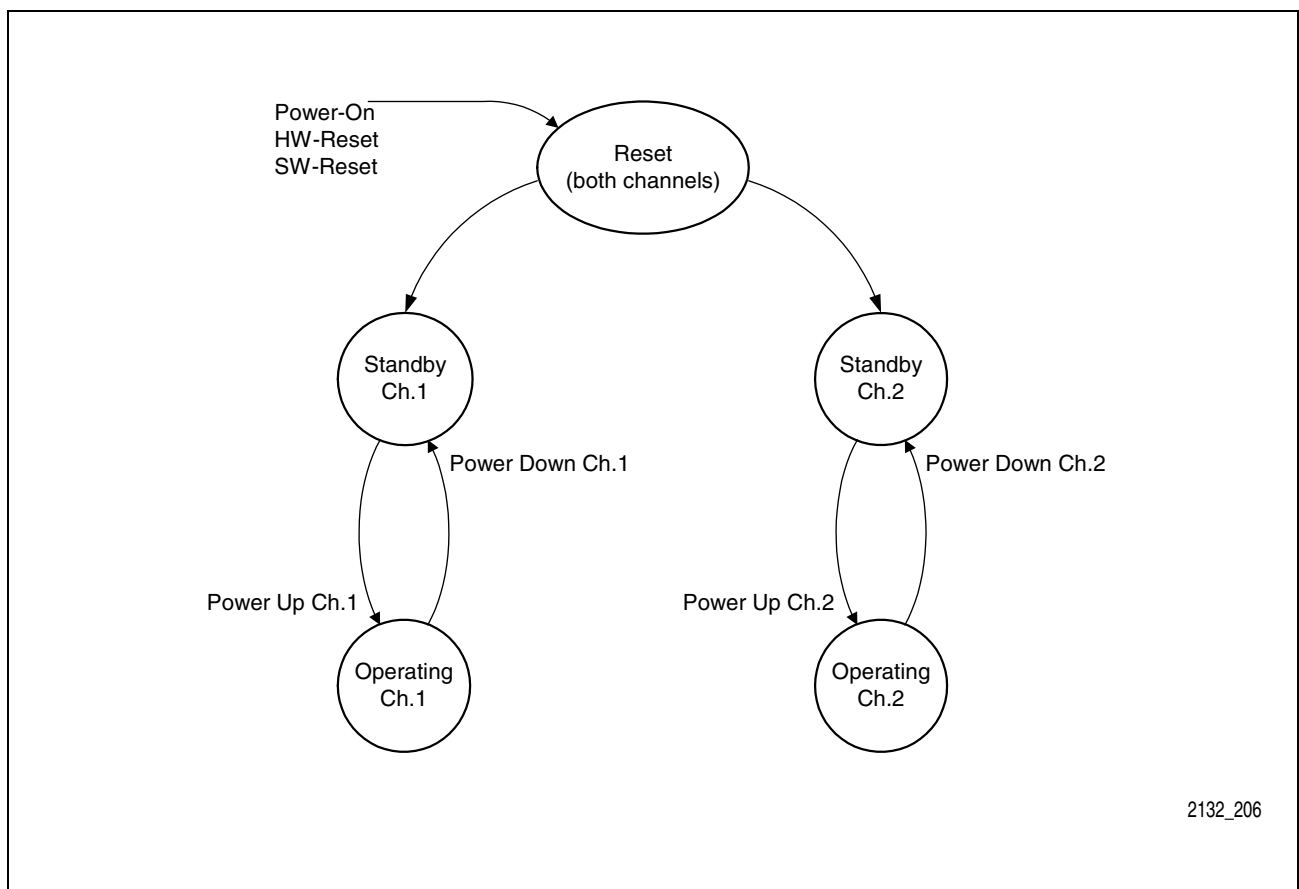

2132_206

Figure 5 SICOFI[®]2-TE State Diagram

4.1.1 Power On

All input pins must be at GND level before applying VDD to the SICOFI[®]2-TE. Otherwise, the device may not enter the Reset State. In this case, the SICOFI[®]2-TE can be reset by HW- or SW-Reset, or can be initialized by setting all registers to zero.

Operational Description
4.1.2 Hardware Reset

Voltage levels lower than 1.2 V applied to Pin 23 (RESET#) for more than 3 μ s will reset the SICOFI[®]2-TE. Spikes that are shorter than 1 μ s will be ignored. When RESET# is released the SICOFI[®]2-TE will enter Standby State.

Table 2 Register Values and Accessibility

Register	SICOFI [®] 2-TE State		
	Reset	Standby	Operating
CR0...CR4	00 _H	user configurable	user configurable
XR0...XR7	00 _H	user configurable	user configurable
CRAM	unchanged	user configurable	user configurable

Table 3 Input and Output Pin Behavior

Pin	SICOFI [®] 2-TE State		
	Reset	Standby	Operating
DIN	ignored	serial input	serial input
DOUT	high impedance	serial output	serial output
DU, DD	inactive	inactive	receiving/transmitting PCM data during programmed time slot
V _{OUT1} , V _{OUT2}	high impedance	high impedance	analog output
V _{IN1} , V _{IN2}	ignored	ignored	analog input
SBx _y	configured as input	programmable as input or output	programmable as input or output
SOx _y	GNDD	digital output	digital output
SIx _y	ignored	digital input	digital input
RGEN	high	programmable frequency	programmable frequency
CHCLK	high	programmable freq. (not 16,384 kHz)	programmable frequency

Note: The 1536 kHz DCL clock must be applied for all device functions.

Table 4 Power Dissipation

No. of Channels Operating	Typical Power Dissipation
None	2.5 mW
1	70 mW
2	90 mW

4.2 Transmission Characteristics

4.2.1 Overload Point

The overload point of the SICOFI[®]2-TE A/D converters is at 2.223 V. This is the peak amplitude of a sine wave level of 1.572 Vrms. Higher input signal levels will be distorted. Theoretical load capacities for A-Law and μ -Law encoded signals are defined in ITU-T Recommendation G.711. These values correspond to the SICOFI[®]2-TE overload point:

Table 5 Maximum Signal Levels

Encoding Law	IOM-2 PCM Interface	Analog Interface
	Theoretical Load Capacity (according to ITU-T G.711)	Max. Sine Wave Level (SICOFI [®] 2-TE Overload Point)
A-Law	3.14 dBm0	1.572 Vrms
μ -Law	3.17 dBm0	

4.2.2 0 dBm0-Levels

The analog voltage levels corresponding to a 0 dBm0 sine wave signal can be calculated from the maximum signal levels shown in **Table 5**. The results are shown in **Table 6**.

Table 6 Analog Voltage Levels Corresponding to 0 dBm0-Level

Encoding Law	Analog Sine Wave Level corresponding to 0 dBm0 PCM Level
A-Law	$1.572 \text{ Vrms} * 10^{(-3.14/20)} = 1.095 \text{ V rms}$
μ -Law	$1.572 \text{ Vrms} * 10^{(-3.17/20)} = 1.091 \text{ V rms}$

Note: Periodic PCM codes for a 1 kHz sine wave signal with 0 dBm0 level can be found in ITU-T G.711.

4.2.3 Compressor Gain Relative to Coding Law

The μ -Law compressor unit of the SICOFI[®]2-TE automatically adds 1.94 dBm0 gain, which has to be considered for the total gain calculation. The accumulated gain of all programmable transmit filters (AX1+AX2+FRX) must not exceed 6 dB if the device is set to μ -Law operation. If the device is set to A-Law operation, then the accumulated gain must not exceed 8 dB.

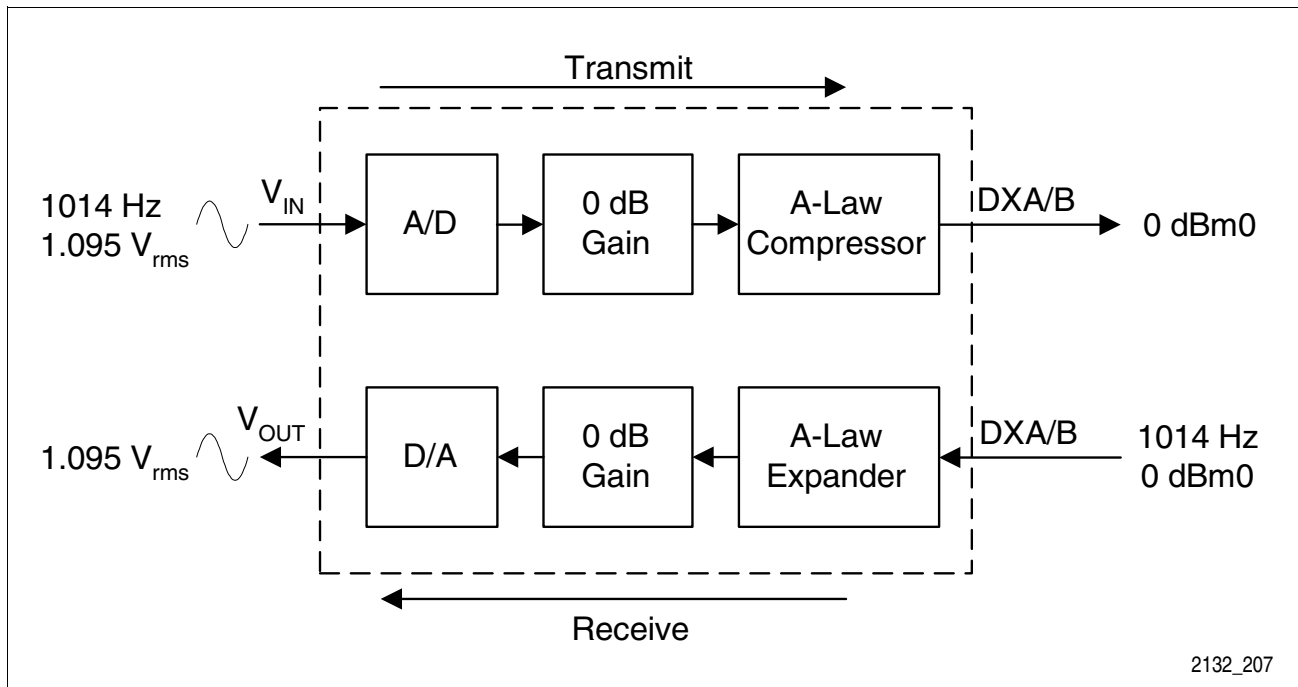

2132_207

Figure 6 Analog and PCM Signal Levels in A-Law Mode

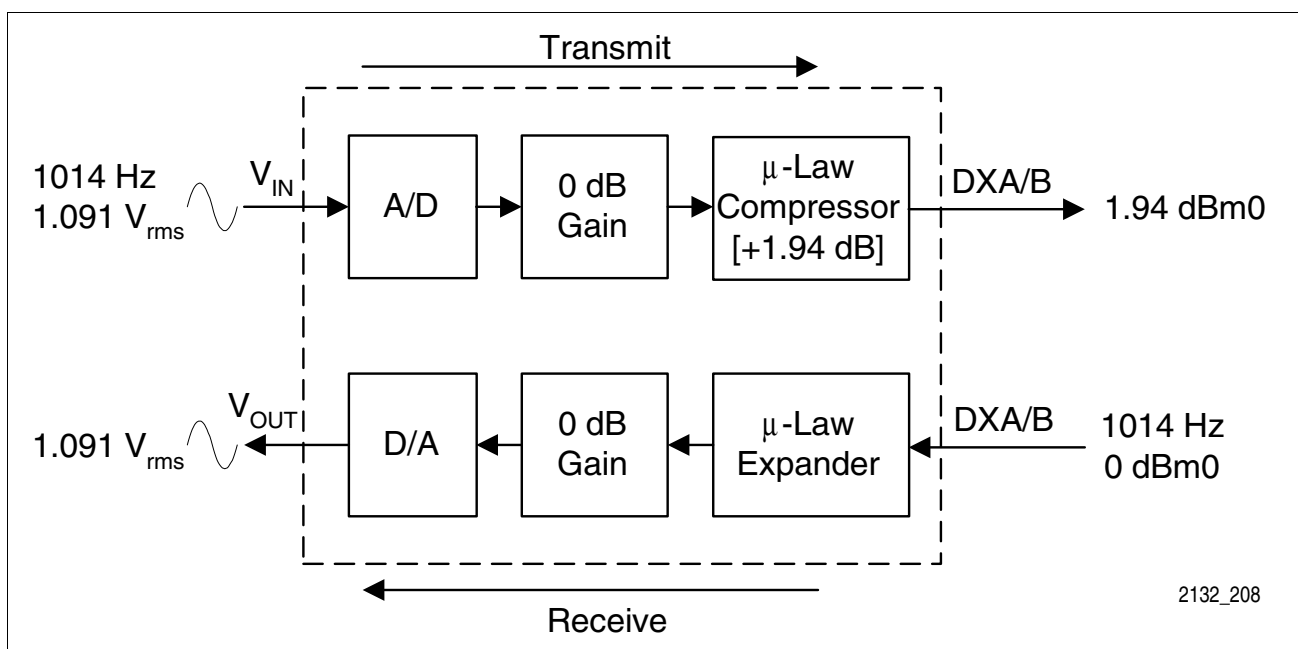

2132_208

Figure 7 Analog and PCM Signal Levels in μ -Law Mode

4.2.4 Operating Conditions

The figures in this document are based on the subscriber-line board requirements. Proper adjustment of the programmable filters (transhybrid balancing, impedance matching, frequency-response correction) requires a complete knowledge of the analog environment in which the SICOFI[®]2-TE is to be used. Unless otherwise stated, the transmission characteristics are guaranteed within the following operating conditions:

- $T_A = 0\text{ }^{\circ}\text{C}$ to $70\text{ }^{\circ}\text{C}$;
- $V_{DD} = 5\text{ V} \pm 5\%$;
- $\text{GNDA}_{1,2,3,4} = \text{GNDD} = 0\text{ V}$;
- Load on V_{OUT} : $R_L > 300\ \Omega$; $C_L < 50\text{ pF}$;
- $H(\text{IM}) = H(\text{TH}) = 0$;
- $H(\text{R1}) = H(\text{FRX}) = H(\text{FRR}) = 1$;
- HPR and HPX enabled;
- $\text{AR} = 0$ to -8 dB ($\text{AR} = \text{AR1} + \text{AR2} + \text{FRR} + \text{R1}$);
- $\text{AX} = 0$ to $+8\text{ dB}$ for A-Law,
 $\text{AX} = 0$ to $+6\text{ dB}$ for μ -Law ($\text{AX} = \text{AX1} + \text{AX2} + \text{FRX}$);
- $f = 1014\text{ Hz}$; 0 dBm_0 ; A-Law or μ -Law;
- $\text{AGX} = 0\text{ dB}$, $+6.02\text{ dB}$; and
- $\text{AGR} = 0\text{ dB}$, -6.02 dB .

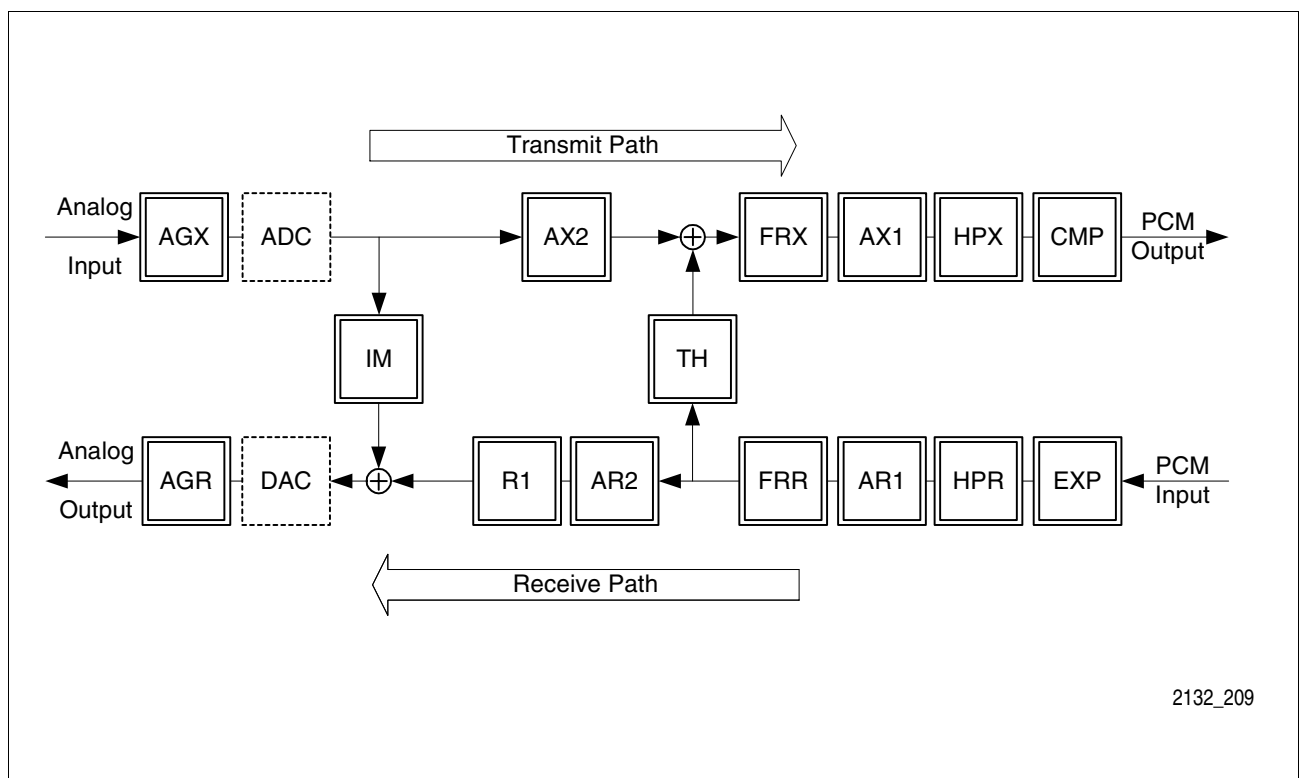

2132_209

Figure 8 Simplified Signal Flow Diagram

4.2.5 Gain Accuracy

Table 7 Gain Accuracy

Parameter	Symbol	Limit Values			Unit	Test Conditions
		min.	typ.	max.		
Absolute Gain	G	-0.80	± 0.10	+0.80	dB	$T_A = 25\text{ }^\circ\text{C}$, $V_{DD} = 5\text{ V}$, AGX = AGR = 0 dB
Variation with Temperature				± 0.05	dB	$T_A = 0\text{ }^\circ\text{C}$ to $70\text{ }^\circ\text{C}$
Variation with Supply Voltage				± 0.05	dB	$V_{DD} = 5\text{ V} \pm 5\%$
Variation with Analog Gain				± 0.05	dB	AGX= +6.02 dB, AGR= -6.02 dB

4.2.6 Gain Tracking (Receive and Transmit)

The gain deviation for a 1014 Hz sine-wave input signal will stay within limits shown in **Table 8**. All values are relative to the gain of a 0 dBm0 input signal.

Table 8 Gain Deviations with Input Level

Input Level	Symbol	Gain Deviation			Unit	Test Conditions
		min.	typ.	max.		
-55 to -50 dBm0	ΔG			± 1.4	dB	1014 Hz sine-wave test signal. Reference level is at 0 dBm0.
-50 to -37 dBm0	ΔG			± 0.5	dB	
-37 to 3 dBm0	ΔG			± 0.25	dB	

4.2.7 Frequency Response

Table 9 Attenuation with Frequency in Transmit and Receive Direction

Input Frequency	Receive Loss		Transmit Loss		Unit	Test Conditions
	min.	max.	min.	max.		
0 Hz to 100 Hz	0		> 2		dB	0 dBm0 input signal level. 1014 Hz reference frequency
100 Hz to 200 Hz	0		0		dB	
200 Hz to 300 Hz	-0.125		-0.125	1	dB	
300 Hz to 3.0 kHz	-0.125	0.125	-0.125	0.125	dB	
3.0 kHz to 3.2 kHz	-0.125	0.3	-0.125	0.3	dB	
3.2 kHz to 3.4 kHz	-0.125	0.65	-0.125	0.65	dB	
> 3.4 kHz	0		0		dB	

4.2.8 Group Delay

4.2.8.1 Group Delay, Absolute Values

Table 10 shows the limit values for the Absolute Group Delay. The maximum delays are valid when the SICOFI[®]2-TE is operating with H(TH) = H(IM) = 0, and H(FRR) = H(FRX) = 1, and include the delay through the A/D and D/A converters. The typical delays are the average of all different time slot delays during one IOM-2 frame.

Table 10 Group Delay, Absolute Values

Parameter	Symbol	Limit Values			Unit	Test Conditions
		min.	typ.	max.		
Transmit Delay	D_{XA}	300	375	450	μ s	0 dBm0 input signal level, f_{Test} at T_G min.
Receive Delay	D_{RA}	300	375	450	μ s	

Operational Description

4.2.8.2 Group Delay Distortion with Frequency

The Group Delay Distortion in transmit and receive direction will stay within the limits shown in **Table 11**. Group Delay Distortion values are referenced to the minimum value of Group Delay (T_{Gmin}).

Table 11 Group Delay Distortion with Frequency

Frequency	Symbol	Limit Values			Unit	Test Conditions
		min.	typ.	max.		
500 Hz to 600 Hz	Δt_G			300	μs	0 dBm0 input signal level, reference point is at T_{Gmin} .
600 Hz to 1.0 kHz	Δt_G			150	μs	
1.0 kHz to 2.6 kHz	Δt_G			100	μs	
2.6 kHz to 3.0 kHz	Δt_G			300	μs	

4.2.9 Noise

Table 12 Idle Channel Noise in Transmit Direction

Parameter	Symbol	Limit Values			Unit
		min.	typ.	max.	
A-Law, psophometric ($V_{IN} = 0 V$)	N_{TP}			-66.0	dBm0p
μ -Law, C-message ($V_{IN} = 0 V$)	N_{TC}			19.0	dBrc0

Table 13 Idle Channel Noise in Receive Direction

Parameter	Symbol	Limit Values			Unit
		min.	typ.	max.	
A-Law, psophometric (idle code + 0)	N_{RP}		-85	-77.0	dBm0p
μ -Law, C-message (idle code + 0)	N_{RC}		5	13.0	dBrc0

4.2.10 Harmonic and Intermodulation Distortion

Table 14 Harmonic and Intermodulation Distortion

Parameter	Symbol	Limit Values			Unit	Test Conditions
		min.	typ.	max.		
Harmonic Distortion 2 nd , 3 rd order	<i>HD</i>		-44		dB	0 dBm0; <i>f</i> = 1014 Hz
Intermodulation	<i>R</i> ₂ <i>IMD</i>		-46		dB	Equal-level, 4-tone method (EIA-464) at composite level of -13 dBm0; <i>f</i> = 300 Hz to 3400 Hz
	<i>R</i> ₃ <i>IMD</i>		-56		dB	

4.2.11 Total Distortion

Table 15 Signal-to-Total Distortion Ratio Measured with Sine Wave

Input Level	Symbol	Min. Values		Unit	Test Conditions
		A-Law	μ -Law		
-45 dB	S/D	23.5	26.0	dB	sine wave <i>f</i> =1014 Hz, receive and transmit, μ-Law: C-message weighted, A-Law: psophometrically weighted.
-40 dB	S/D	28.5	30.0	dB	
-30 dB	S/D	34.5	34.5	dB	
> -28 dB	S/D	35.4	35.4	dB	

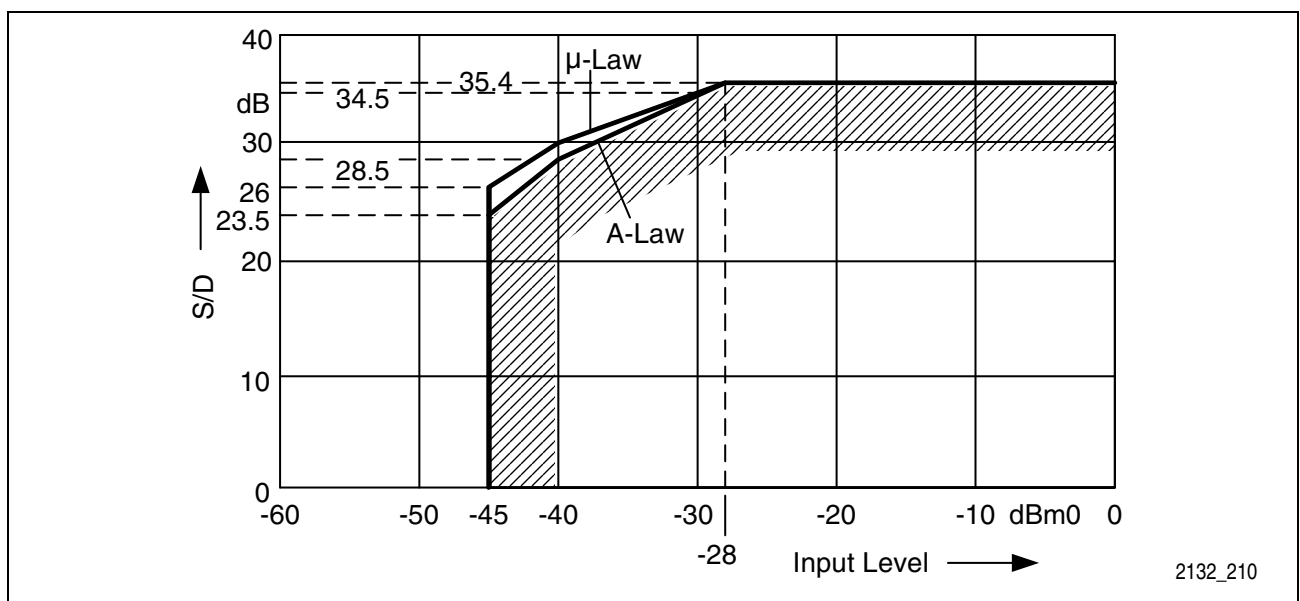

Figure 9 Total Distortion Measured with Sine-Wave, Receive and Transmit

4.2.12 Single Frequency Distortion

Table 16 Single Frequency Distortion

Test Input Signal	Frequency Range	max. Input Level
Receive Direction	300 Hz to 3.4kHz	0 dBm0
Transmit Direction	0 Hz to 12 kHz	0 dBm0

Any resulting signal with a frequency different from the test input signal will stay at least 28 dB below the input signal level.

4.2.13 Overload Compression

This is measured with a 1014 Hz sine-wave signal. The overload point in μ -Law Mode is at 3.17 dBm0.

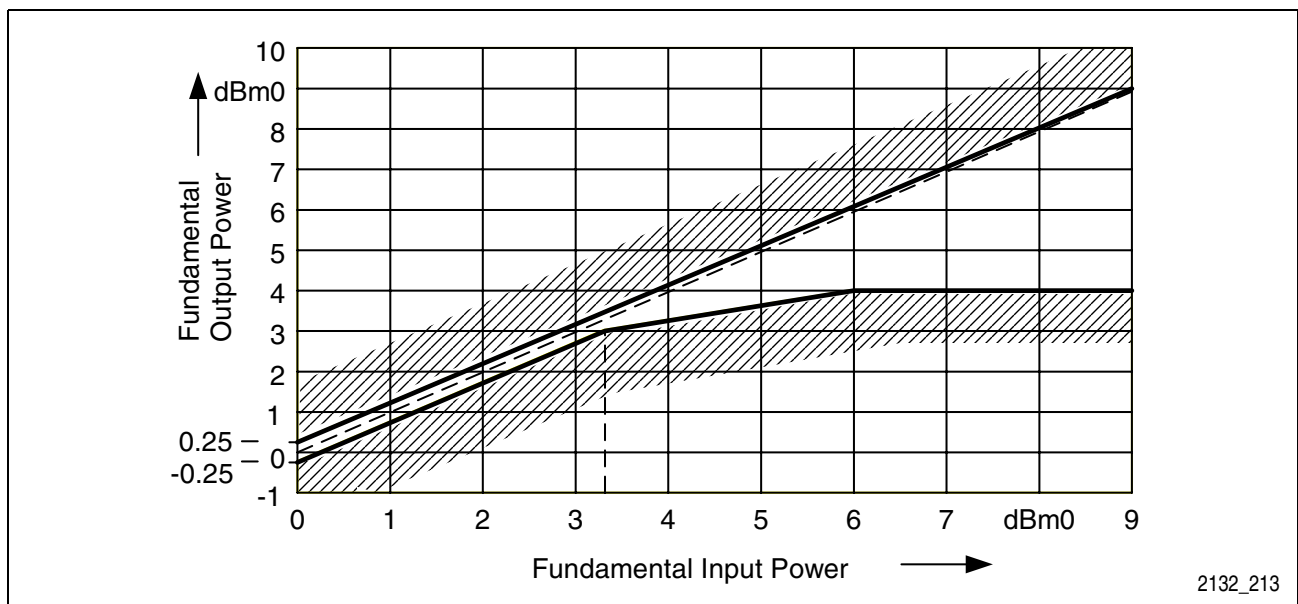

Figure 10 Overload Compression (μ -Law Coding, Transmit Direction)

4.2.14 Crosstalk

Table 17 Crosstalk Between Channels

Parameter	Symbol	Limit Values			Unit	Test Conditions
		min.	typ.	max.		
Crosstalk, 0dBm0	<i>CT</i>		- 80	- 75	dB	$f = 200$ Hz to 3400 Hz, any combination of directions and channels

4.2.15 Out-of-Band Discrimination in Transmit Direction

With any 0 dBm0 sine-wave signal below 100 Hz and in the range from 3.4 kHz to 100 kHz (out-of-band signal) applied to an analog input (V_{INx}), the level of any resulting frequency component at the digital output will stay at least X dB (see **Table 18**) below the output level of a 0 dBm0 1kHz sine-wave reference signal at the analog input.

Table 18 Out-of-Band Signals Applied to the Analog Inputs (V_{INx})

Input Frequency	Min. Output Signal Rejection X	Unit	Test Conditions
0 Hz to 60 Hz	25	dB	0 dBm0 sine-wave input signal on V_{IN}
60 Hz to 100 Hz	10	dB	
3.4 kHz to 4 kHz	$-14 \left(\sin \left(\pi \frac{4000-f}{1200} \right) - 1 \right)$	dB	
4 kHz	15	dB	
4 kHz to 4.6 kHz	$-18 \left(\sin \pi \frac{4000-f}{1200} \right) - \frac{7}{9}$	dB	
4.6 kHz to 100 kHz	40	dB	

The Hardware Filters behind the A/D Converters reject teletax pulses with their poles at 12 kHz \pm 150 Hz and 16 kHz \pm 150 Hz.

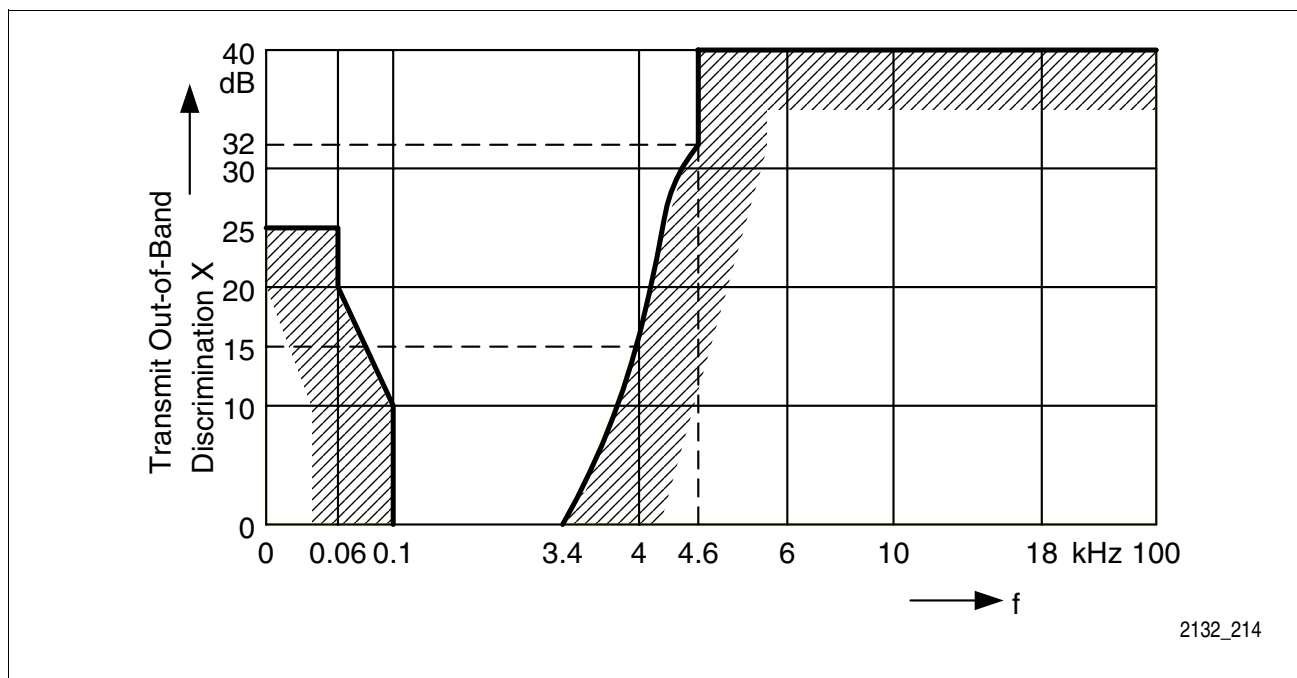

Figure 11 Out-of-Band Discrimination in Transmit Direction

4.2.16 Out-of-Band Discrimination in Receive Direction

With any 0 dBm0 sine-wave frequency in the range from 300 Hz to 3.99 kHz applied to the digital input (DU or DD), the level of any resulting out-of-band signal at the analog output will stay at least X dB (see **Table 19**) below the output level of a 0 dBm0 1kHz sine-wave reference signal at the digital input.

Table 19 Out-of-Band Signals at the Analog Outputs (V_{OUTx})

Output Frequency	Min. Output Signal Rejection X	Unit	Test Conditions
3.4 kHz to 4.6 kHz	$-14 \left(\sin \left(\pi \frac{4000-f}{1200} \right) - 1 \right)$	dB	0 dBm0 sine-wave input signal on digital input (DU or DD)
4.6 kHz to 10.55 kHz	$35 + 22 \frac{f-4600}{5950}$	dB	
4 kHz	15	dB	
4.6 kHz	28	dB	
>10.55 kHz	57	dB	

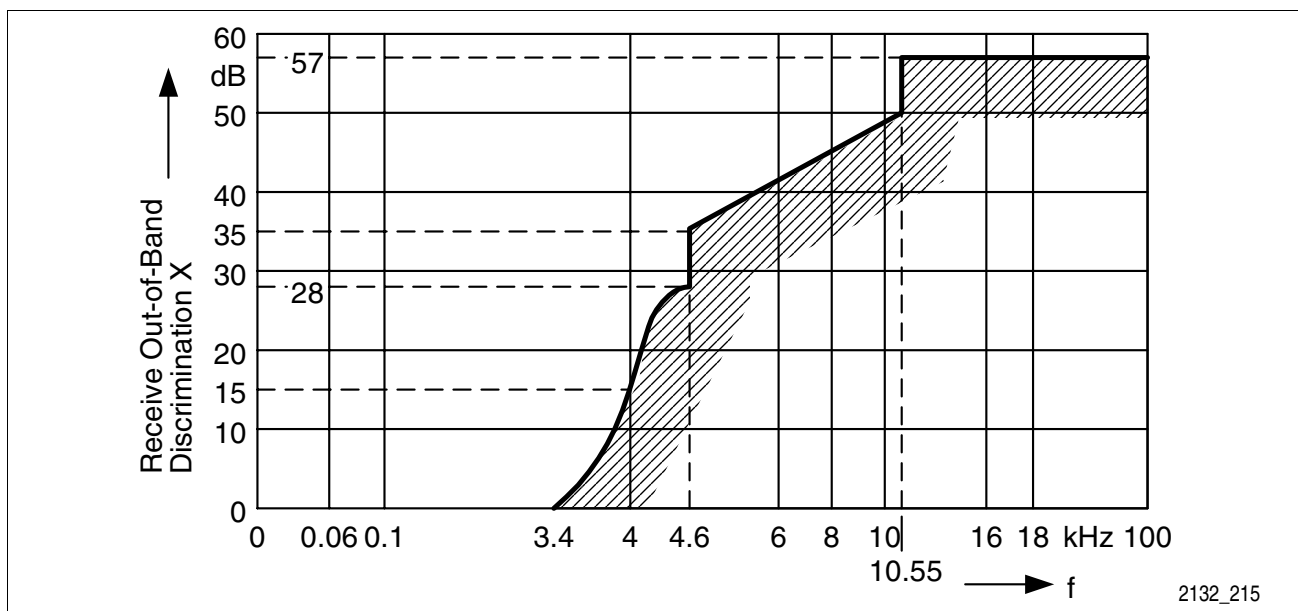

Figure 12 Analog Output: Out-of-Band Signals

4.2.17 Out-of-Band Idle Channel Noise at Analog Output

With an idle code (any sequence of constant PCM octets) applied to the digital input, the level of any resulting out-of-band power spectral density at the analog output, measured with 3 kHz bandwidth, will be not greater than the limit curve shown in **Figure 13**.

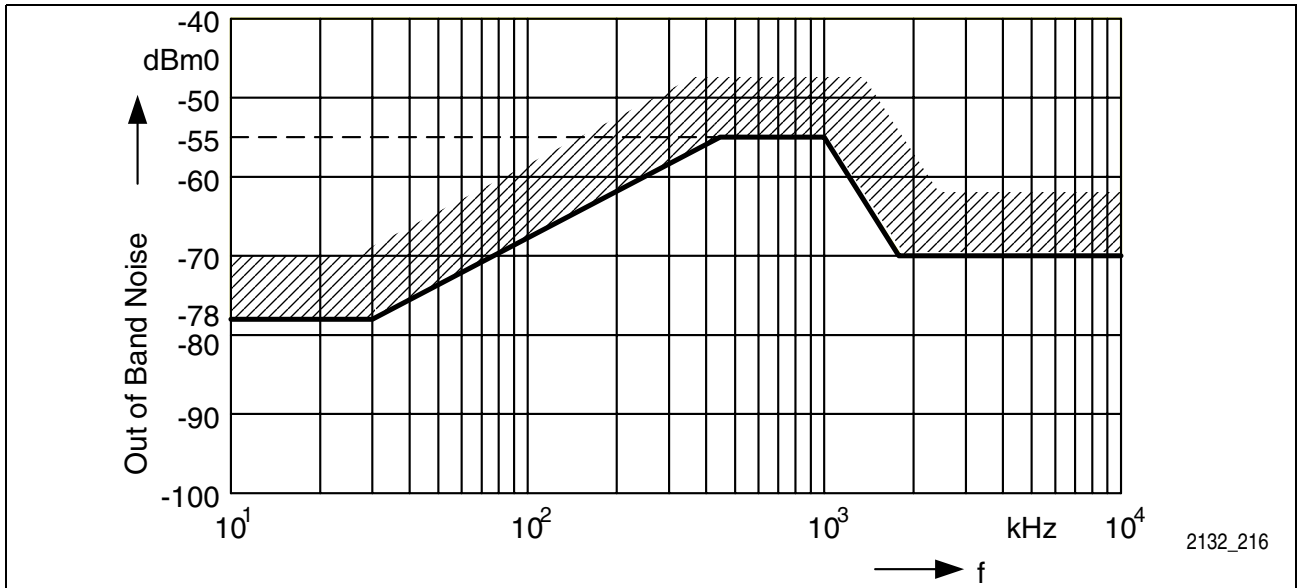

Figure 13 Analog Output: Out-of-Band Idle Channel Noise

4.2.18 Transhybrid Loss

The quality of Transhybrid-Balancing is very sensitive to deviations in gain, group delay, and deviations inherent to the A/D- and D/A-converters, as well as to all external components used with a tip/ring interface (SLIC, OP's etc.).

Transhybrid loss test setup:

The SICOFI®2-TE test loop “DLB-ANA” is selected (see **Figure 31**), which connects the analog output with the analog input. The programmable filters FRR, AR, FRX, AX are by-passed. The IM-filter is disabled, ($H(IM)=0$). The balancing filter TH is enabled with optimized coefficients for this configuration ($V_{OUT} = V_{IN}$).

A 0 dBm0 sine wave signal with a frequency in the range of 300 Hz to 3400 Hz is applied to the digital input. The signal levels of the resulting echo at the digital output will stay below the values shown in **Table 20**.

Table 20 Transhybrid Loss

Input Frequency	Symbol	Transhybrid Loss		Unit	Test Condition
		min.	typ.		
300 Hz	THL ₃₀₀	19	40	dB	$T_A = 25\text{ °C}; V_{DD} = 5\text{ V}$ AGX = AGR = 0 dB; typical variation of amplitude: $\pm 0.15\text{ dB}$ delay: $\pm 0.5\text{ }\mu\text{s}$.
500 Hz	THL ₅₀₀	25	45	dB	
2500 Hz	THL ₂₅₀₀	21	40	dB	
3000 Hz	THL ₃₀₀₀	19	35	dB	
3400 Hz	THL ₃₄₀₀	19	35	dB	

5 Interface Description

The SICOFI[®]2-TE provides four interfaces:

- Analog Interface,
- IOM-2 PCM Interface,
- Signaling Interface, and
- Serial Microcontroller Interface.

A general description of these interface is given in the **Product Overview, Chapter 4**. Refer to the **Programmers Reference Manual** for information on the configuration and operation of the four interfaces.

The subsequent chapters in this manual explain how to connect the SICOFI[®]2-TE to subscriber line interface circuits (SLICs), microcontrollers, and IOM-2 Interface.

5.1 Analog Interface

The Analog Interface in combination with a Subscriber Line Interface Circuit (SLIC) forms a configurable tip/ring (t/r) telephone line. The AC transmission characteristic of the SICOFI[®]2-TE—SLIC combination can be controlled by programming the digital filter structures inside the SICOFI[®]2-TE. The correct filter coefficients are determined by the targeted AC transmission behavior (e.g. Telco specification) and by the transfer functions of the SLIC.

The SICOFI[®]2-TE can be interfaced directly to electronic SLICs or transformer solutions. The high driving capability of up to 300 Ohms eliminates the need for an external amplifier that is normally used with transformer SLICs.

The peak amplitude of the analog inputs and outputs is at 2.223 V (overload point).

Out-of-band signals applied to the analog inputs are suppressed by the on-chip digital hardware filters. The poles of these filters are fixed at 12 kHz and 16 kHz which suppresses the echo signal from teletax pulses very efficiently: As long as the amplitude of the teletax echo stays below the overload threshold of 2.223 V_p (1.57 V_{rms}), the voice signal in the transmit path will not be disturbed. Thus, the on-chip hardware filters can eliminate the need for external teletax filters.

5.1.1 Coupling Capacitors at the Analog Interface

A coupling capacitor >39 nF must be used on the V_{IN} -pins in the transmit direction. The required value for the coupling capacitor on the V_{OUT} -pins depends on the input resistance of the SLIC-circuitry (R_{Load}). It has to be chosen to fulfil the frequency response requirement in the receive direction. **Figure 14** can be used to determine an appropriate value for the coupling capacitor (C_{Ext1}).

Interface Description

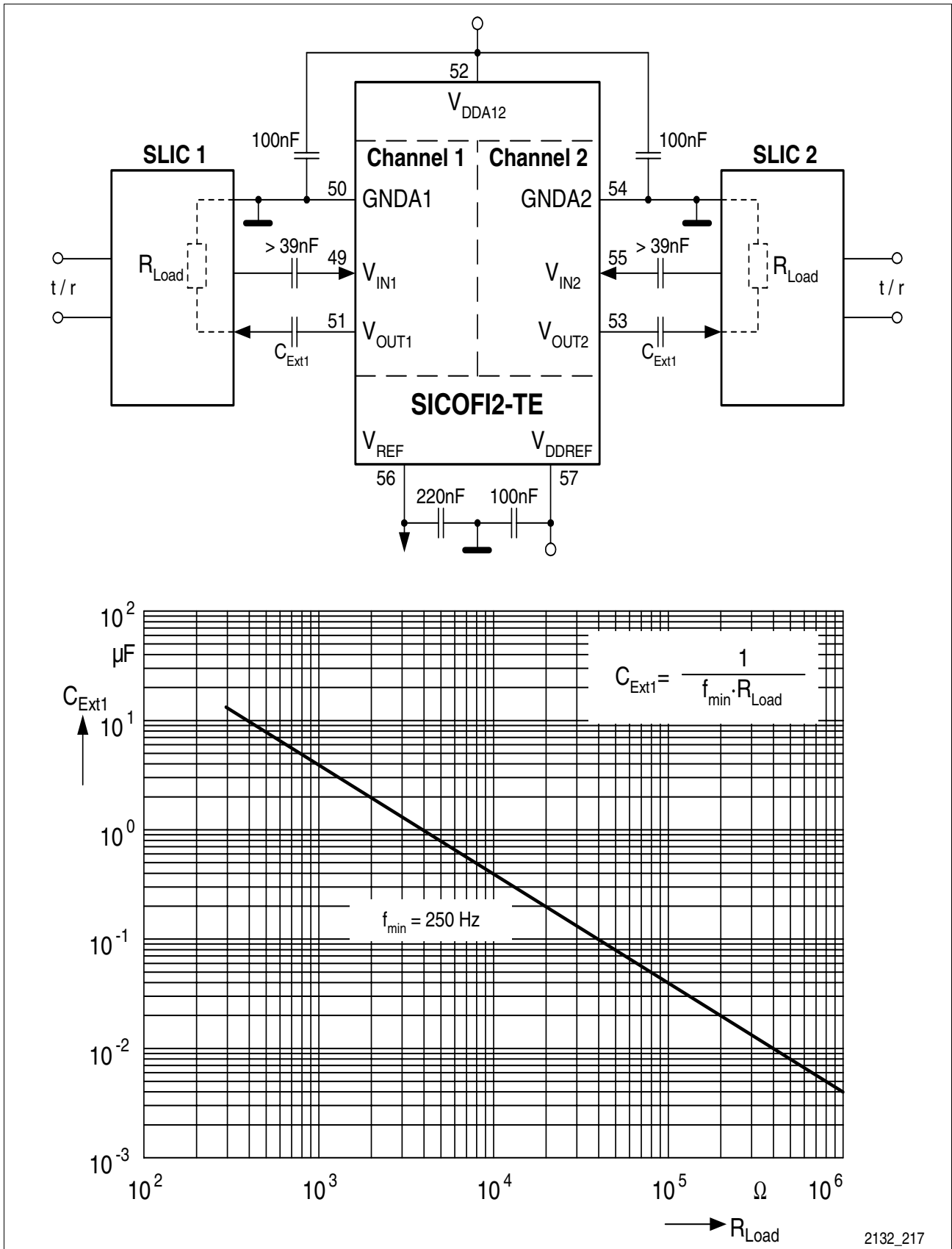

Figure 14 Analog Interface to Two Subscriber Line Interface Circuits (SLICs)

5.1.2 Analog Interface Pins

Table 21 Analog Interface Pins

Symbol	Pin	Function
V_{IN1}	49	Analog Input, Channel 1, 2
V_{IN2}	55	Requires a coupling capacitor >39 nF to the SLIC, see Figure 14 .
V_{OUT1}	51	Analog Output, Channel 1, 2
V_{OUT2}	53	Requires a coupling capacitor to the SLIC. The capacitor's value depends on the input impedance of the SLIC, see Figure 14 .
GND A1	50	Analog Ground, Channel 1, 2
GND A2	54	Not internally connected to GNDD or the other GNDAx.
V_{DDA12}	52	Analog Supply Voltage, Channels 1+2 +5 V (100 nF blocking capacitor required, see Figure 14).
V_{DDREF}	57	Analog Supply Reference Voltage, +5 V (100 nF blocking capacitor required, see Figure 14).
V_{REF}	56	Reference Voltage Must connect to a 220 nF cap. to ground, see Figure 14 .

5.2 IOM-2 PCM Interface

The SICOFI[®]2-TE's IOM-2 PCM Interface can be connected directly to an IOM-2 interface in terminal mode (3 IOM channels, 768 kbit/s). The device uses the IOM-clock DCL at 1536 kHz as a master clock. The bit clock input BCL can be at either 768 kHz or 1536 kHz. FCS is an 8 kHz input. The SICOFI[®]2-TE has data input Pin 30 and data output Pin 26 assigned to the IOM Data Upstream signal, DU. Further, input Pin 27 and output Pin 29 are assigned to the IOM Data Downstream signal, DD. This configuration allows transmission and reception of PCM data on either DU or DD. It further enables internal connections of channels, by programming the receive time slot of one channel to the transmit time slot of the other channel, and vice versa.

The IOM-2 PCM Interface has the following characteristics and features:

- Data rate of 768 kbit/s,
- Bit clock input (BCL) configurable for 768 kHz or 1536 kHz,
- IOM-2 DCL signal used as 1536 kHz master clock for the device; must be applied for all device functions,
- 12 time slots per IOM-2 frame,
- PCM data format serialized 8 bits with MSB first,
- Configurable A-Law or μ -Law coding,
- Independent time slot assignment for each channel and direction,
- Internal voice connection between channels possible,
- Programmable sampling slopes,
- Programmable frame delay.

5.2.1 IOM-2 PCM Interface Pins

Table 22 IOM-2 PCM Interface Pins

Symbol	Pin	Function
DCL	22	Master Clock input, 1536 kHz.
BCL	32	Bit Clock input at 768 kHz or 1536 kHz.
FSC	31	Frame Synchronization Clock, 8 kHz.
DD	27	Data Downstream input, connect to Pin 29.
DU	30	Data Upstream input, connect to Pin 26.
DU	26	Data Upstream output, connect to Pin 30.
DD	29	Data Downstream output, connect to Pin 27.

5.2.2 IOM-2 PCM Time Slot Configuration in TE Mode

Each voice channel should be assigned to one of the following time slots: B1, B2, IC1, IC2, IC3, or IC4. **Figure 15** and **Table 23** illustrate the time slot and bit positions resulting from the programming example below:

Table 23 IOM-2 Time Slot Selection

IOM-2 Time Slot	Reception on:		Transmission on:	
	DD	DU	DU	DD
B1	CR4 = 0000 0000	CR4 = 1000 0000	CR5 = 0000 0000	CR5 = 1000 0000
B2	CR4 = 0000 0001	CR4 = 1000 0001	CR5 = 0000 0001	CR5 = 1000 0001
IC1	CR4 = 0000 0100	CR4 = 1000 0100	CR5 = 0000 0100	CR5 = 1000 0100
IC2	CR4 = 0000 0101	CR4 = 1000 0101	CR5 = 0000 0101	CR5 = 1000 0101
IC3	CR4 = 0000 1000	CR4 = 1000 1000	CR5 = 0000 1000	CR5 = 1000 1000
IC4	CR4 = 0000 1001	CR4 = 1000 1001	CR5 = 0000 1001	CR5 = 1000 1001

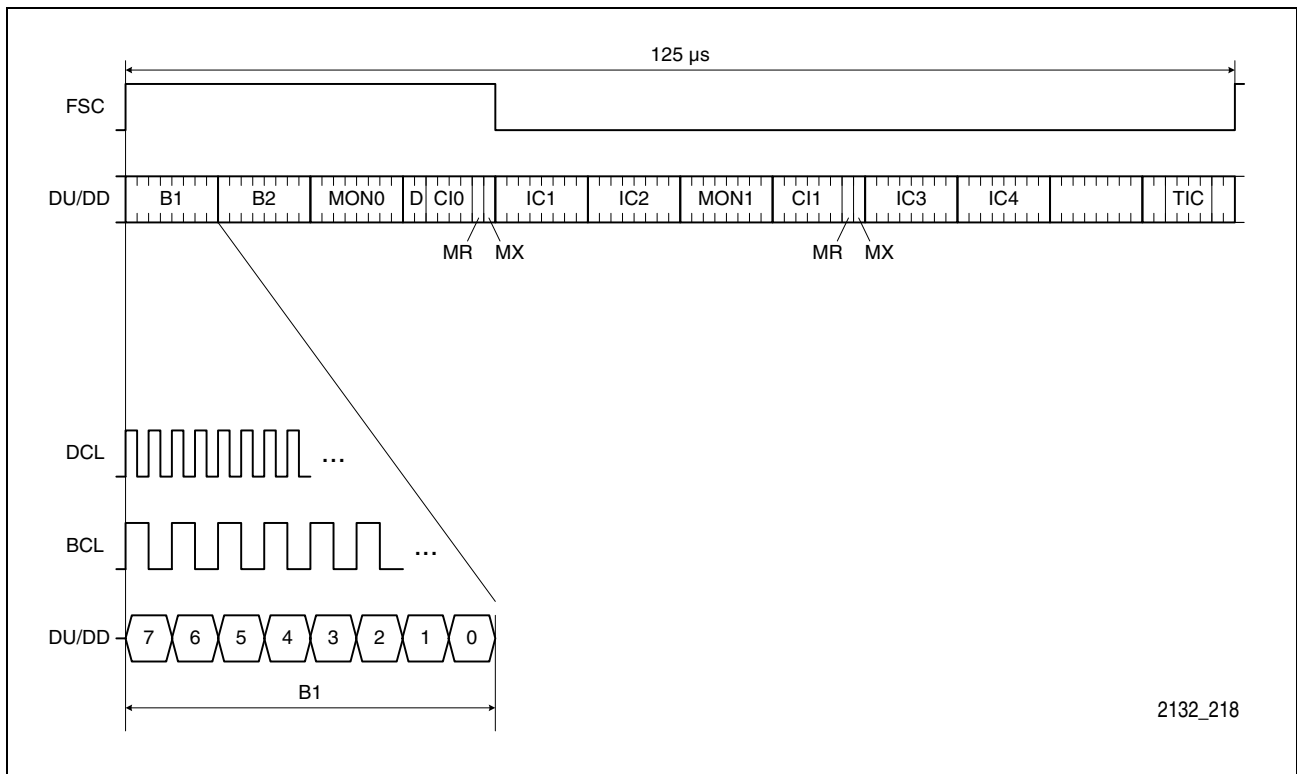

2132_218

Figure 15 IOM-2 PCM Interface Time Slot Positions

5.3 Signaling Interface

The SICOFI[®]2-TE Signaling Interface is used to monitor and control supervision and signaling functions on up to four subscriber lines. The device generates interrupt signals to indicate signaling status changes on any of the input pins.

The Signaling Interface consists of the following I/O pins and functions:

- 14 signaling pins (2 input pins, 2 output pins, and 3 user-configurable bi-directional pins per channel),
- Debouncing functions,
- 1 interrupt output, indicating changes on any of the signaling inputs,
- 1 output signal for ringing,
- 1 chopper clock output.

5.3.1 Signaling Interface Pins

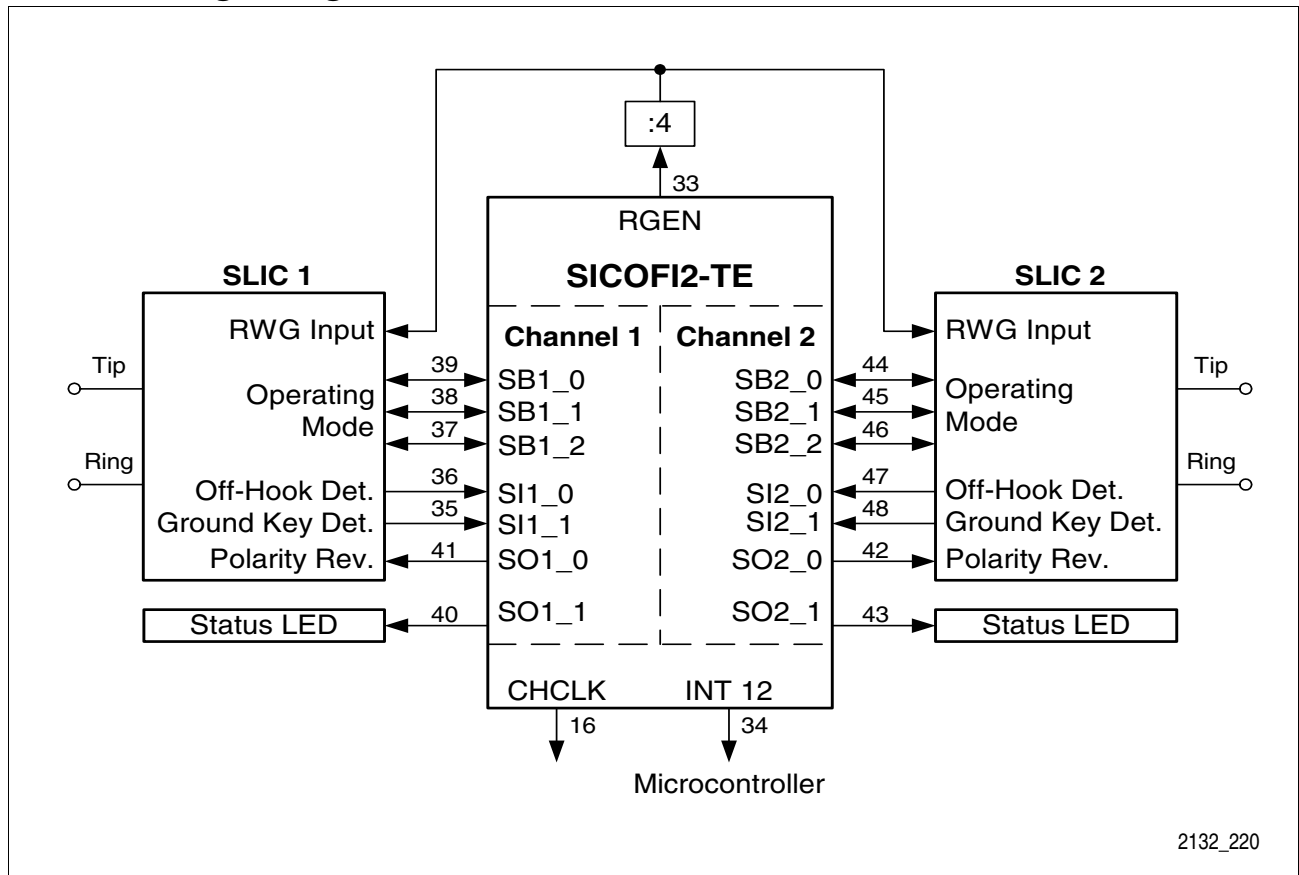

2132_220

Figure 16 Signaling Example: Two Subscriber Lines

Table 24 Signaling Interface: Pins and Functions for SLIC Interfaces

Table 25

Channel 1			Channel 2		
Pin	Symbol	Function	Pin	Symbol	Function
36	SI1_0	Signaling Input 0	47	SI2_0	Signaling Input 0
35	SI1_1	Signaling Input 1	48	SI2_1	Signaling Input 1
41	SO1_0	Signaling Output 0	42	SO2_0	Signaling Output 0
40	SO1_1	Signaling Output 1	43	SO2_1	Signaling Output 1
39	SB1_0	Bi-directional Signaling 0	44	SB2_0	Bi-directional Signaling 0
38	SB1_1	Bi-directional Signaling 1	45	SB2_1	Bi-directional Signaling 1
37	SB1_2	Bi-directional Signaling 2	46	SB2_2	Bi-directional Signaling 2
34	INT12	Interrupt Output, Channels 1+2, active high			

5.3.2 Debouncing Functions and Interrupt Generation

All signaling inputs are sampled at programmable intervals (Field N in register XR4). If all the inputs assigned to one channel-pair (1&2) have been stable for two subsequent samples their values are stored in the signaling registers and the associated interrupt output (INT12) is set high. The debouncing functions and interrupt generation require a 1536 kHz signal on Pin 22 (DCL). If, for power savings reasons, DCL is temporarily disabled, a signaling change interrupt can be generated by external hardware. Refer to the *Programmer's Reference Manual* for further details on this function.

5.3.3 Clock Output Signals

Two programmable Clock Output signals are provided by the PSB 2132:

- RGEN (Pin 33) divided by two can drive the ring input of a ringing SLIC. It is configured in register XR4.Field T.
- CHCLK (Pin 16) is configured in register XR5.CHCLK.
- CHCLK = 16,384 kHz: Requires at least one channel in POWER-UP state.

Table 26 Clock Programming

REGEN		CHCLK	
XR4.Field T	Output (Pin 33)	XR5.CHCLK	Output (Pin 16)
0000	High level (+5V)	00	High level (+5V)
0001 to 1110	Clock period = T *2ms (min. 2 ms, max. 28 ms)	01	512 kHz signal
		10	256 kHz signal
1111	Low level (0V)	11	16,384 kHz signal

5.4 Serial Microcontroller Interface

The Serial Microcontroller Interface is used to access the SICOFI[®]2-TE's internal registers and the Coefficient RAM (CRAM). The Serial Microcontroller Interface consists of four pins: two data pins (DIN, DOUT), one clock pin (DCLK) and one pin for chip select (CS#). If DIN and DOUT are strapped together, only three microcontroller I/O pins are required to build this interface.

Interface Description

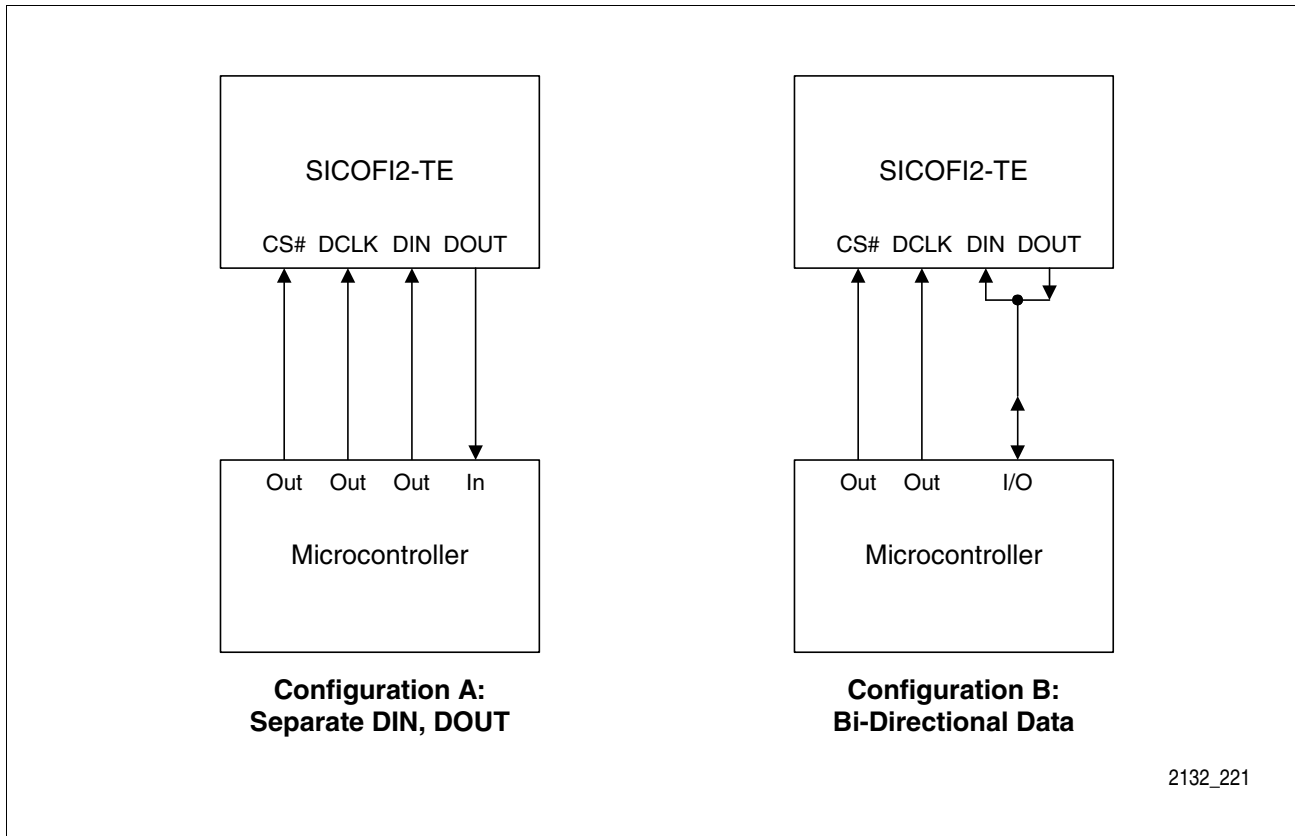

Figure 17 Serial Microcontroller Interface

5.4.1 Serial Microcontroller Interface Pins

Table 27 Serial Microcontroller Interface: Pins and Functions

Symbol	Pin	Function
CS#	17	Chip Select, enable to read or write data, active low.
DCLK	18	Data Clock, shifts data from or to device; max. clock rate is 8192 kHz.
DIN	19	Control Data Input; sampled with rising edge of DCLK.
DOUT	20	Control Data Output; bits are shifted with the falling edge of DCLK; DOUT is in high impedance state when no data is transmitted from the SICOFI [®] 2-TE.

5.4.2 Write Access

Following a falling edge of CS#, the first eight bits received on DIN specify the type of command. The data bytes following a write command are stored in the selected configuration registers or the selected part of the Coefficient RAM. The number of data bytes depends on the type of command. After every command CS# must be set to '1'.

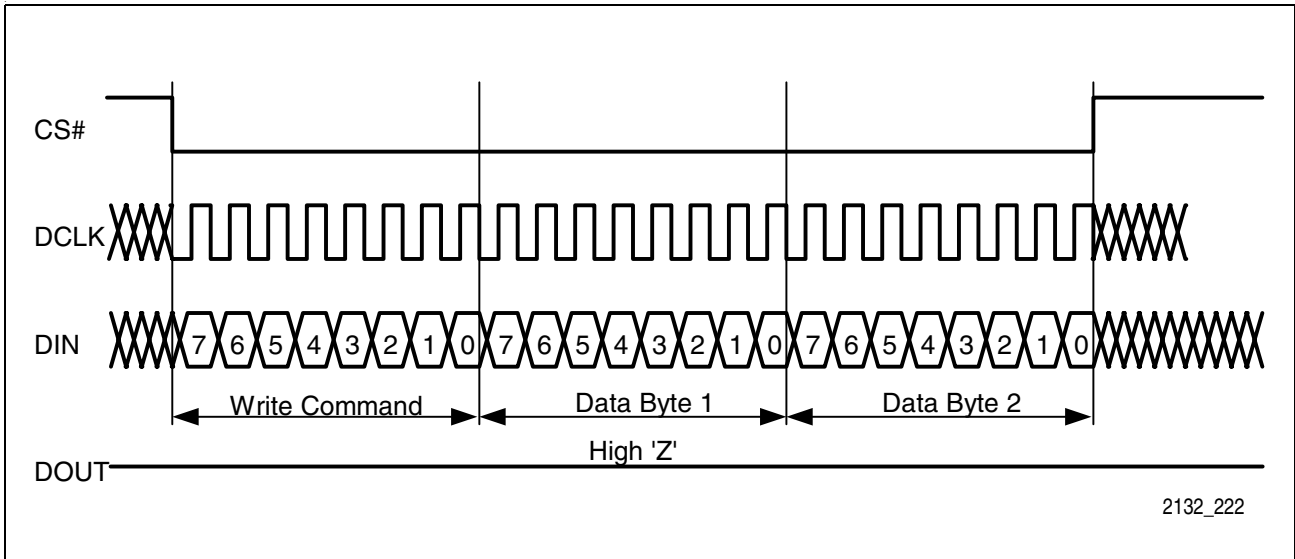

Figure 18 Example for a Two-Byte Write Access

5.4.3 Read Access

If the first eight bits received via DIN represent a read command, the SICOFI[®]2-TE will initiate its response via DOUT. An identification byte (81_H) is followed by the requested number of data bytes (contents of configuration registers or contents of the CRAM). During execution of a read command, the device will ignore data on DIN. After every command CS# must be set to '1'.

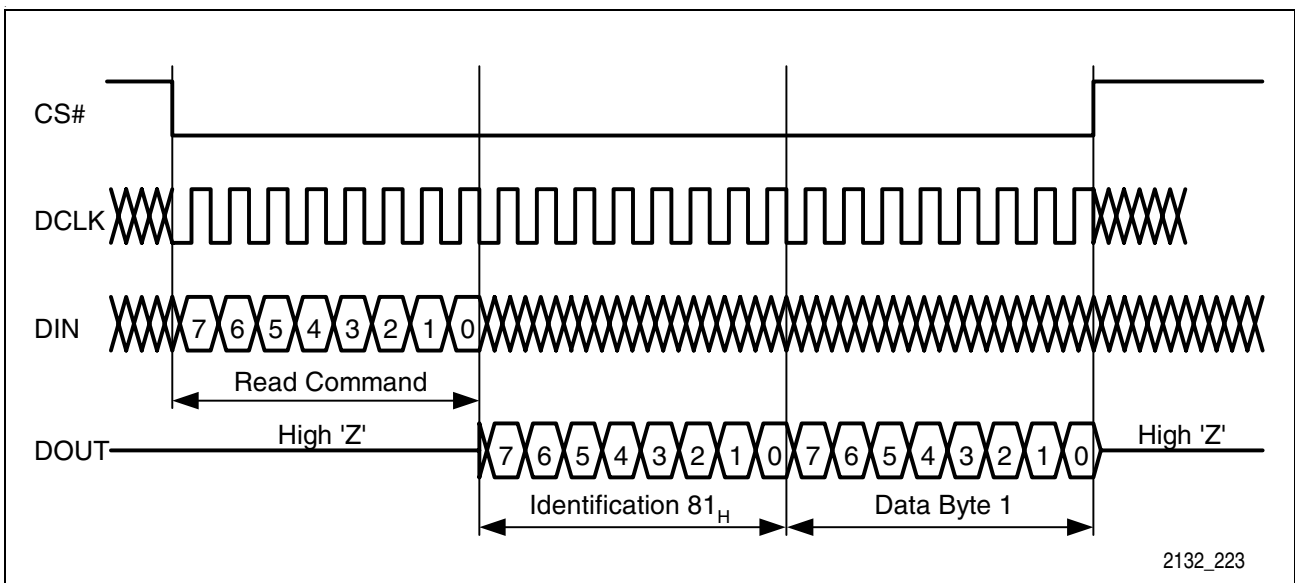

Figure 19 Example for a One-Byte Read Access

For byte-by-byte transfer, the high time of DCLK can be prolonged, resulting in a user-defined 'waiting time' between bytes. This mechanism can be used for writing to and reading from the device.

Interface Description

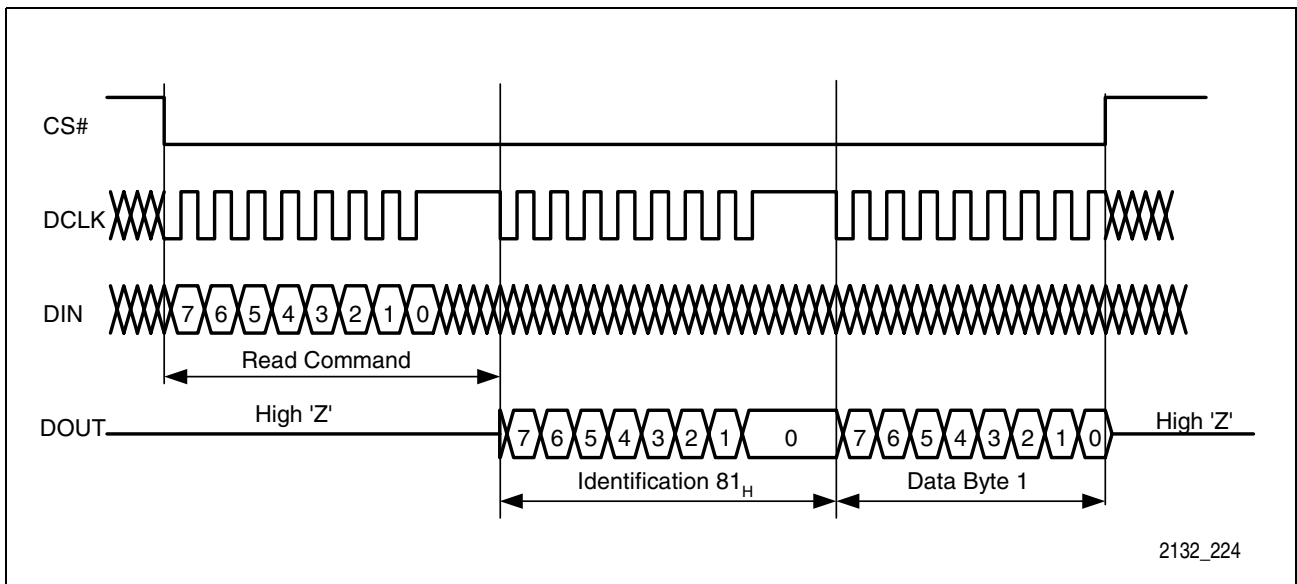

Figure 20 Example for a Read Access with Byte-by-Byte Transfer

Read and write commands can be chained by leaving CS# low after the completion of each command sequence.

For read or write access to individual registers, the command sequence may be terminated by rising CS# after the transmission of any number of bytes.

5.4.4 Three-Wire Access

DIN and DOUT may be strapped together and connected to a single I/O pin of the microcontroller. The interface remains fully functional with only three wire connections. After every command CS# must be set to '1'.

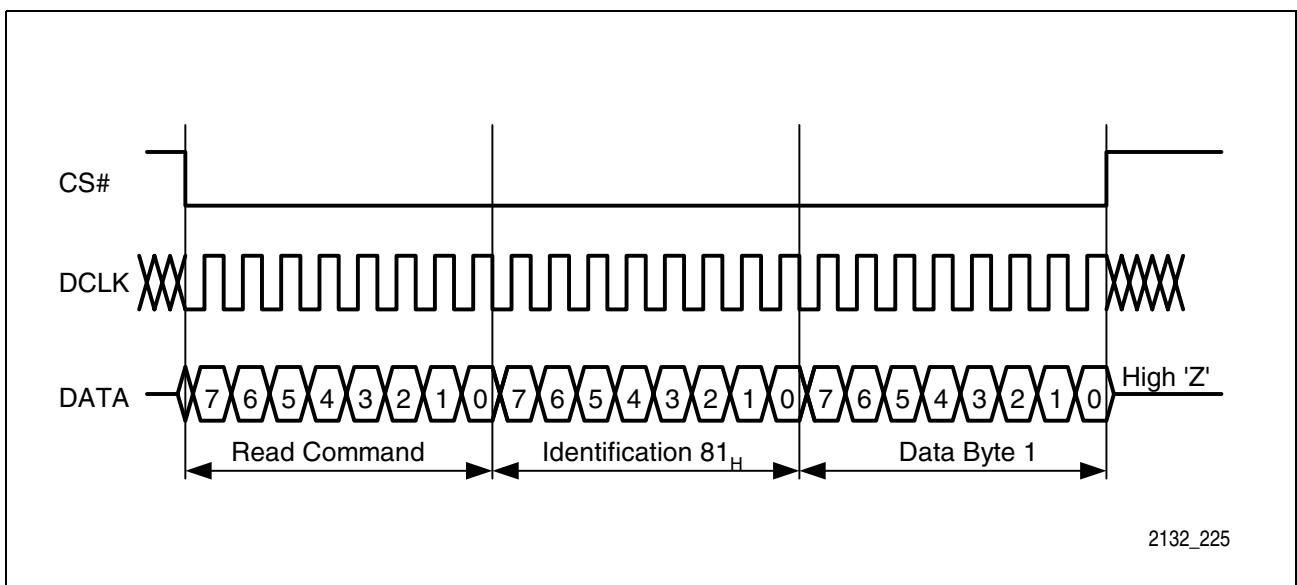

Figure 21 Bi-Directional Data Signal: DIN and DOUT Strapped Together

6 Programming Overview

The transmission characteristics and interfaces of the PSB 2132 can be adapted to various environments. Configuring the functional blocks and programming the digital filter behavior is accomplished by loading values to the Configuration Registers and the Coefficient RAM (CRAM). Software utilities are available to determine the appropriate register and CRAM values (see *Programmer’s Reference Manual*).

6.1 Programming Overview

The SICOFI[®]2-TE has eight Common Configuration Registers (XR0 to XR7). Settings in these registers affect all two channels.

Each of the two channels has six Channel-Specific Configuration Registers (CR0 to CR5). Settings in these registers affect only the designated channel.

The filters of each channel are individually programmable through channel-specific coefficients in CRAM. There are two global sets of TH Filter coefficients that can be assigned to either channel. All of the filter blocks and their locations are illustrated in **Figure 8**.

6.1.1 Register Model

Channel-specific and Common Configuration Registers and coefficients are shown in **Table 28**.

Table 28 Register Model

Configuration Registers and CRAM	Channel Usage
XR0 to XR7 (8 bytes)	common
CR0 to CR5 (6 bytes)	channel-specific
IM/R1 Coefficients (16 bytes)	
FRR, FRX Coefficients (16 bytes)	
AR1, AR2, AX1, and AX2 Coefficients (8 bytes)	
TG1 and TG2 Coefficients (8 bytes)	
TH Coefficient Set 1 (24 bytes)	one coefficient set per channel
TH Coefficient Set 2 (24 bytes)	

6.1.2 Register Maps

Table 29 Read Access to Common Configuration Register (XR) Map

	Bit 7	Bit 6	Bit 5	Bit 4	Bit 3	Bit 2	Bit 1	Bit 0
XR0	0	0	0	0	SI2_1	SI2_0	SI1_1	SI1_0
XR1	0	0	0	0	SB2_1	SB2_0	SB1_1	SB1_0
XR2	0	0	0	0	PSB2_1	PSB2_0	PSB1_1	PSB1_0
XR3	0	0	SB2_2	SB1_2	0	0	PSB2_2	PSB1_2
XR4	Field N (Signal Debounce)				Field T (Configure RGEN)			
XR5	0	0	CR_DU	CR_DD	CHCLK		Version	
XR6	C-Mode	X-S	R-S	DRV_0	Shift	PCM-OFFSET		
XR7	OF7	OF6	OF5	OF4	OF3	OF2	OF1	OF0

Table 30 Write Access to Common Configuration Register (XR) Map

	Bit 7	Bit 6	Bit 5	Bit 4	Bit 3	Bit 2	Bit 1	Bit 0
XR0	0	0	0	0	SO2_1	SO2_0	SO1_1	SO1_0
XR1	0	0	0	0	SB2_1	SB2_0	SB1_1	SB1_0
XR2	0	0	0	0	PSB2_1	PSB2_0	PSB1_1	PSB1_0
XR3	0	0	SB2_2	SB1_2	0	0	PSB2_2	PSB1_2
XR4	Field N (Signal Debounce)				Field T (Configure RGEN)			
XR5	0	0	CR_DU	CR_DD	CHCLK		Version	
XR6	C-Mode	X-S	R-S	DRV_0	Shift	PCM-OFFSET		
XR7	OF7	OF6	OF5	OF4	OF3	OF2	OF1	OF0

Table 31 Channel-Specific Configuration Register (CR) Map (Read & Write)

	Bit 7	Bit 6	Bit 5	Bit 4	Bit 3	Bit 2	Bit 1	Bit 0
CR0	TH	IM/R1	FRX	FRR	AX	AR	TH-SEL	
CR1	ETG2	ETG1	PTG2	PTG1	LAW	0	0	PU
CR2	COT/R			0	IDR	LM	LMR	V+T
CR3	TEST-Loops				AGX	AGR	D-HPX	D-HPR
CR4	RLINE	0	0	0	RS3	RS2	RS1	RS0
CR5	XLINE	0	0	0	XS3	XS2	XS1	XS0

6.1.3 CRAM Structure

Coefficient RAM (CRAM) is used to store the individual coefficients calculated for each channel. The coefficients can be written and read through the Microcontroller Interface. The IM, FRX, FRR, AX, AR, TG1, TG2, and TH coefficients are accessed through the Coefficient Operation (COP) Command Sequences which include the channel address (see *Programmer’s Reference Manual Chapter 6.5*).

Channel-specific coefficients always belong to their designated channel. Common coefficients (TH) can be assigned to any of the two channels through field TH-SEL in CR0 (see **Figure 22**).

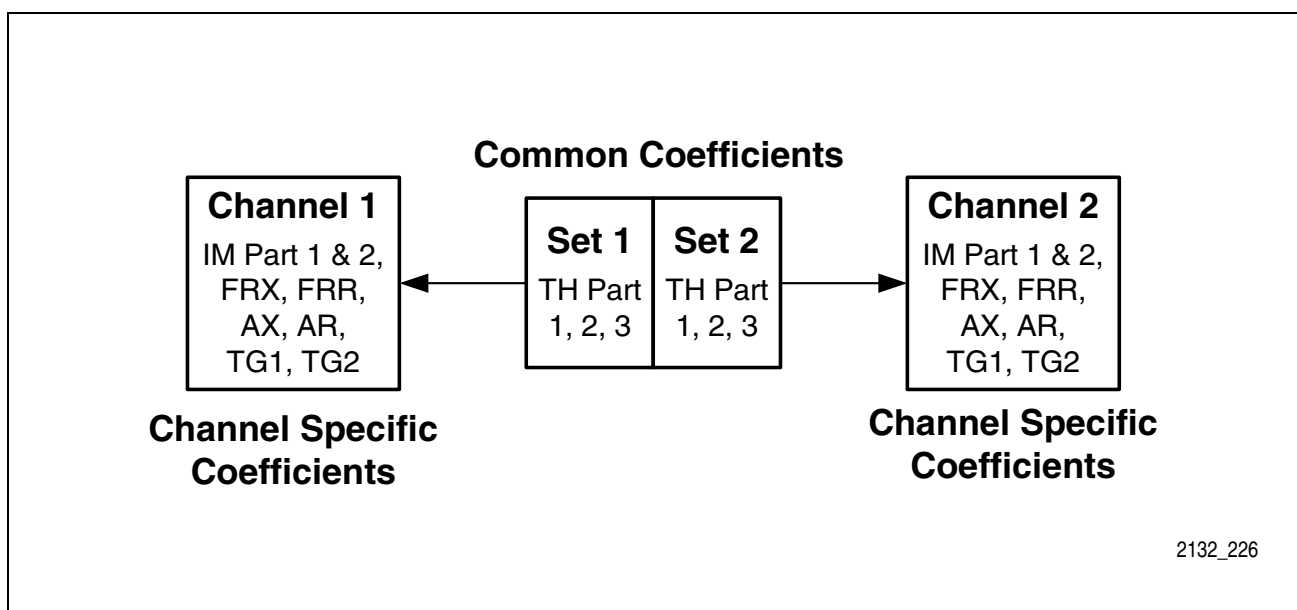

Figure 22 Channel-Specific and Common Coefficients

Table 32 Coefficient RAM (CRAM) Structure per Channel

IM Part 1	8 Coefficient Bytes
IM Part 2	8 Coefficient Bytes
FRX	8 Coefficient Bytes
FRR	8 Coefficient Bytes
AX	4 Coefficient Bytes
AR	4 Coefficient Bytes
TG1	4 Coefficient Bytes
TG2	4 Coefficient Bytes

Table 33 Coefficient RAM (CRAM) Structure per Set

TH Part 1	8 Coefficient Bytes
TH Part 2	8 Coefficient Bytes
TH Part 3	8 Coefficient Bytes

6.2 Types of Commands and Data Bytes

Coefficients and register contents are programmed and accessed through command sequences via the Microcontroller Interface. There are three types of command sequences:

- **Extended Operation (XOP)** for access to the Common Configuration Registers (XR0 to XR7) including the Control Registers for the signaling interface.
- **Status Operation (SOP)** for access to the Channel-Specific Registers (CR0 to CR5), e.g. enabling and disabling of filters, time slot assignment, and test loops.
- **Coefficient Operation (COP)** for access to the CRAM structures. Coefficients can be written to the SICOFI[®]2-TE, and also read back.

Table 34 Types of Commands and Data Bytes.

	7	6	5	4	3	2	1	0
XOP	RST	0	RW	1	1	LSEL		
SOP	AD		RW	1	0	LSEL		
COP	AD		RW	0	CODE			

With the first byte received via DIN, a command type is selected through bits 3 and 4. A two-bit address field (AD) in the COP and SOP commands allows access to the channel-specific structures (CRAM and CR registers). Since the XR Registers are common for all channels, no address field is required within the XOP command byte.

All three commands allow read and write access, which is indicated by bit 5 (RW). The bit fields LSEL and CODE specify the type and the length of data that follows the command.

7 Application Hints

7.1 Support Tools

7.1.1 Development Board

The Evaluation Package EASY 2466 includes the following hardware:

- One SICOFI[®]2-TE Evaluation Board STUT 2466 with connectors for four optional SLIC daughter cards and BNC connectors to a PCM backplane.
- One microcontroller board EVC50x with RS-232 interface that translates data from a PC to SICOFI[®]2-TE format.
- Two SLIC Babyboards STUT 5502 with HARRIS SLIC HC 5502 mounted.

The QSICOS software enables the calculation of the coefficients and the download of the setup file to the evaluation board.

This setup allows measurements and optimization of the actual behavior of a complete transmission system. The EASY 2466 evaluation system connects directly to industry-standard test equipment.

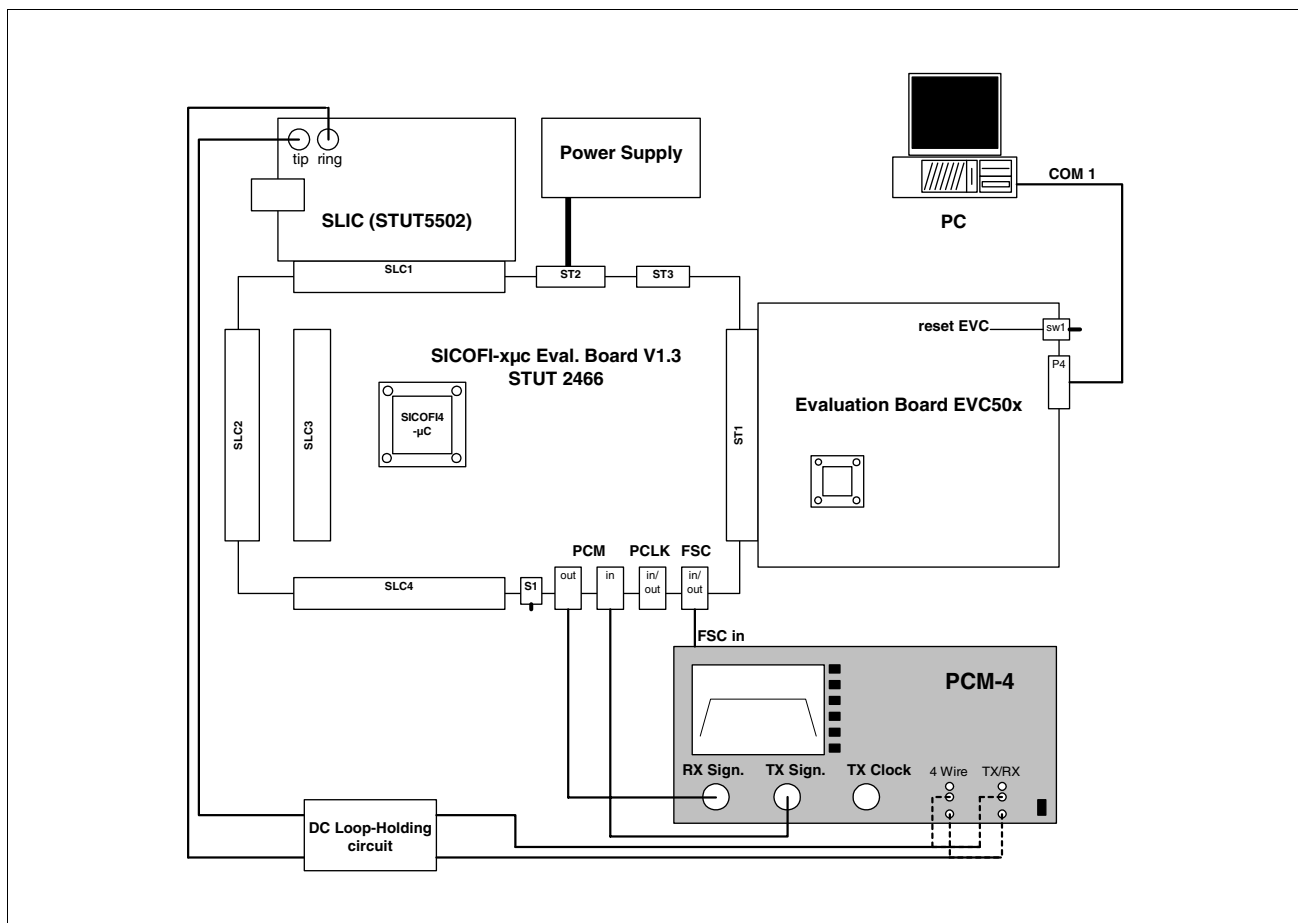

Figure 23 Development System with STUT 2466 Evaluation Board

7.2 Guidelines for Board Design

7.2.1 Filter Capacitors

- For high frequency noise rejection, use 100 nF SMD ceramic capacitors on pins V_{DDA12} , V_{DDA} and V_{DDREF} and connect to GNDA. Additional 2.2 μF tantalum capacitors are recommended.
- Use one 100 nF SMD ceramic capacitor on pin V_{DDDD} and connect to GNDD.
- Use a 1 μF – 10 μF tantalum capacitor from +5 V supply to GND (central blocking).

Note: All blocking capacitors MUST be placed as close as possible to the SICOFI[®]2-TE pins.

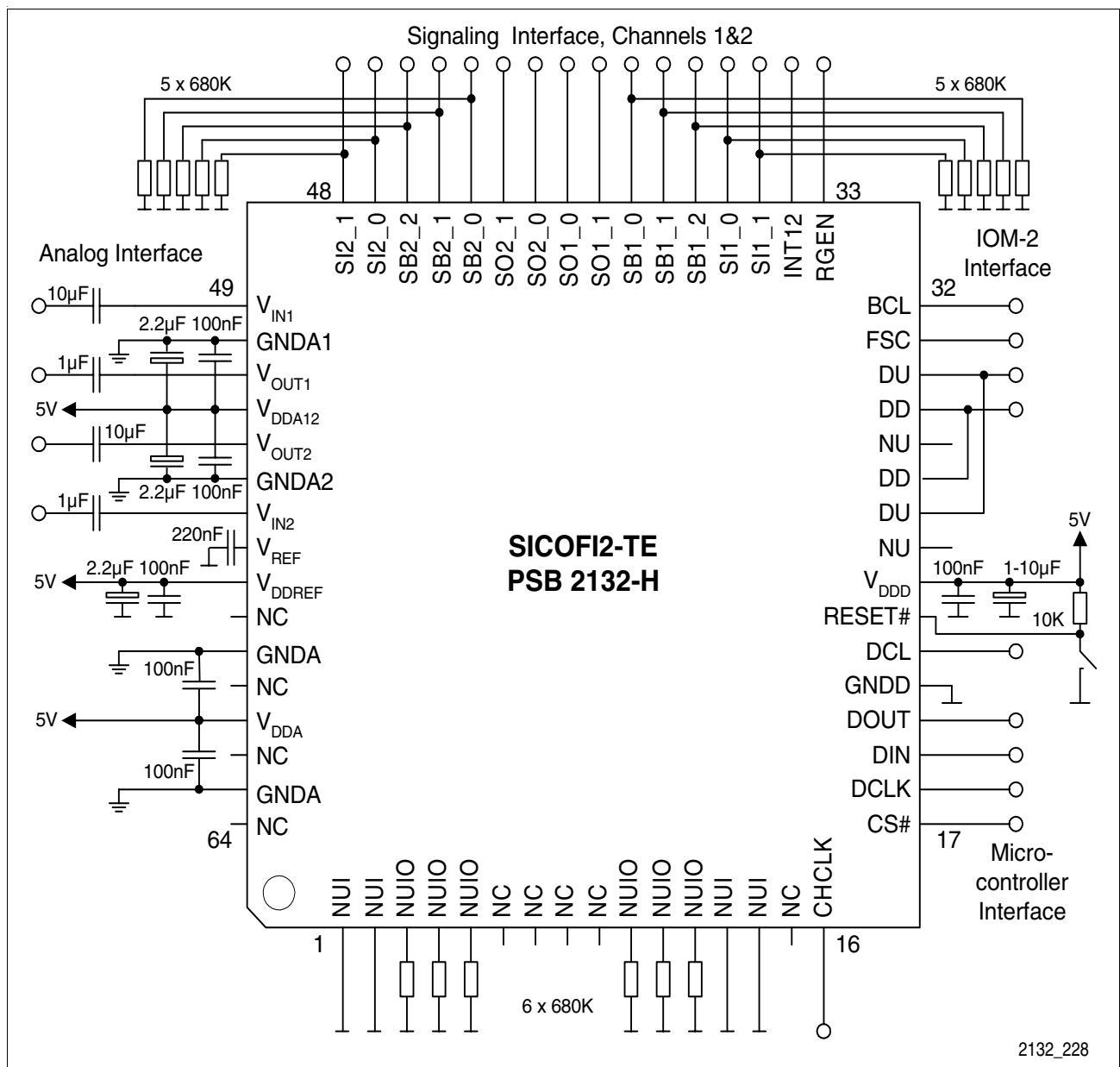

Figure 24 SICOFI[®]2-TE Test Circuit Configuration

7.3 Proposal for SICOFI[®]2-TE Board Design

For a new layout design it is recommended to use a separate ground-layer which gives the possibility to connect all ground-pins of the SICOFI[®]2-TE (GNDA and GNDD) low-ohmic together.

Furthermore, an optimum board layout should follow these recommendations

- Separate all digital supply lines from analog supply lines as far as possible
- Applying the standard practice regarding blocking capacitors is recommended
- Place all SLIC circuits as close as possible to the Vinx/Voutx pins of the SICOFI
- Separate all analog circuitry (especially SLIC and Vinx/Voutx) as far as possible from any digital signal source (esp. clock signals)

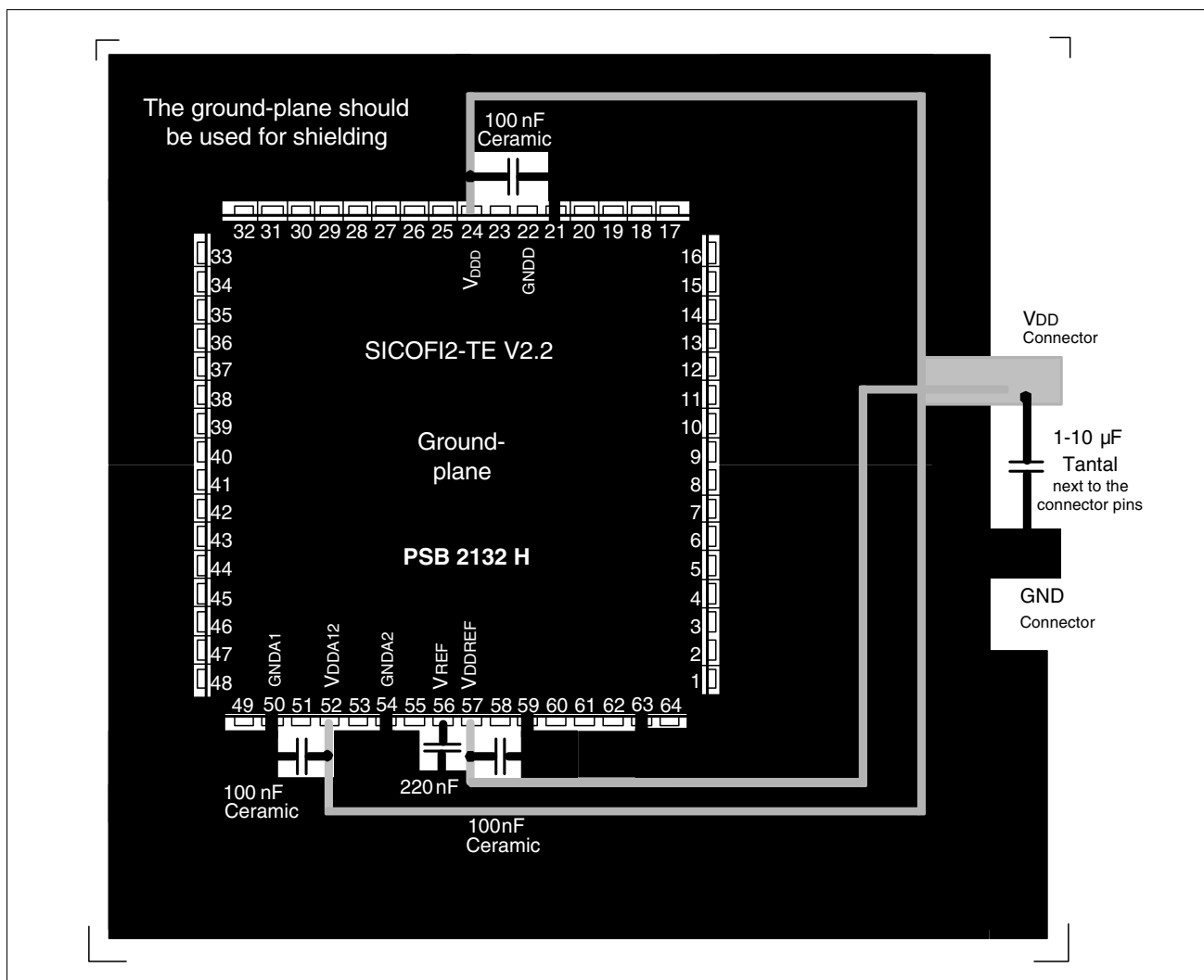

Figure 25 Proposal for a Ground Concept

V_{DD} is the grey colored layer and the Ground-plane is the black colored layer. The Ground-plane should be on both sides of the board on the top and on the ground layer.

8 Electrical Characteristics and Timing Diagrams

8.1 Absolute Maximum Ratings

Parameter	Symbol	Limit Values		Unit	Test Condition
		min.	max.		
V_{DD} referred to GNDD		-0.3	7.0	V	
GNDA to GNDD		-0.6	0.6	V	
Analog input and output voltage Referred to $V_{DD} = 5\text{ V}$; Referred to GNDA = 0 V		-5.3 -0.3	0.3 5.3	V V	
All digital input voltages Referred to GNDD = 0 V; ($V_{DD} = 5\text{ V}$) Referred to $V_{DD} = 5\text{ V}$; (GNDD = 0 V)		-0.3 -5.3	5.3 0.3	V V	
DC input and output current at any input or output pin (free from latch-up)			10	mA	
Storage temperature	T_{STG}	-60	125	°C	
Ambient temperature under bias	T_A	-10	80	°C	
Power dissipation (package)	P_D		1	W	

Note: Stresses above those listed here may cause permanent damage to the device. Exposure to absolute maximum rating conditions for extended periods may affect device reliability.

Electrical Characteristics and Timing Diagrams

8.2 Operating Range

 $V_{DD} = 5\text{ V} \pm 5\%$; $GNDD = 0\text{ V}$; $GNDA = 0\text{ V}$; $T_A = 0\text{ }^\circ\text{C}$ to $+70\text{ }^\circ\text{C}$

Parameter	Symbol	Limit Values			Unit	Test Condition
		min.	typ.	max.		
V_{DD} supply current:	I_{DD}					FSC = 8 kHz, FSC, DCL, BCL active no loads, PCM idle codes, $V_{IN} = 0\text{ V}$.
Standby			0.5	1.0	mA	
1 channel operating				14	25	
2 channels operating			18	30	mA	
Power supply rejection ratio (either direction)	$PSRR$	30			dB	Ripple: sine wave 1014 Hz, 70 mVrms, on every supply pin, AGX=AGR=AX=AR=0dB (see Chapter 4.2.4)

8.3 Digital Interface

 $V_{DD} = 5\text{ V} \pm 5\%$; $GNDD = 0\text{ V}$; $GNDA = 0\text{ V}$; $T_A = 0\text{ }^\circ\text{C}$ to $+70\text{ }^\circ\text{C}$

Parameter	Symbol	Limit Values		Unit	Test Condition
		min.	max.		
Input voltages:					
Low level	V_{IL}	-0.3	0.8	V	
High level	V_{IH}	2.0		V	
Output voltages:					
Low level	V_{OL}		0.45	V	$I_{OL} = -2\text{ mA}$
Low level	V_{OL}		0.8	V	$I_{OL} = -5\text{ mA}$
High level	V_{OH}	4.4		V	$I_{OH} = 0.4\text{ mA}$
High level	V_{OH}	4.0		V	$I_{OH} = 2\text{ mA}$
High level	V_{OH}	2.4		V	$I_{OH} = 5\text{ mA}$
Input leakage current	V_{IL}		± 1	μA	$-0.3 \leq V_{IN} \leq V_{DD}$

Electrical Characteristics and Timing Diagrams
8.4 Analog Interface
 $V_{DD} = 5\text{ V} \pm 5\%$; $GNDD = 0\text{ V}$; $GNDA = 0\text{ V}$; $T_A = 0\text{ }^{\circ}\text{C}$ to $+70\text{ }^{\circ}\text{C}$

Parameter	Symbol	Limit Values			Unit	Test Condition
		min.	typ.	max.		
Input resistance	R_i	160	270	380	k Ω	$0 \leq V_{IN} \leq V_{DD}$
Output resistance	R_o			0.25	Ω	
Output load	R_L	300			Ω	
	C_L			50	pF	
Input leakage current	I_{IL}		± 0.1	± 1.0	μA	$0 \leq V_{IN} \leq V_{DD}$
Input offset voltage	V_{IO}			± 50	mV	
Output offset voltage	V_{OO}			± 50	mV	
Input voltage range (AC)	V_{IN}			± 2.223	V	

8.4.1 Coupling Capacitors at the Analog Interface

Coupling capacitors are required on pins V_{IN} and V_{OUT} .

The recommended value for V_{IN} is $>39\text{ nF}$. The required value for the V_{OUT} capacitor depends on the input impedance of the SLIC (see **Figure 14** in **Chapter 5.1**).

8.5 Reset Timing

To reset the SICOFI[®]2-TE to Reset State, logic low pulses applied to pin RESET# must be below 1.2 V (TTL-Schmitt-Trigger Input) and must persist longer than 3 μs .

Note: Spikes shorter than 1 μs will be ignored.

Electrical Characteristics and Timing Diagrams

8.6 IOM-2 PCM-Interface Timing

8.6.1 Single Clocking Mode

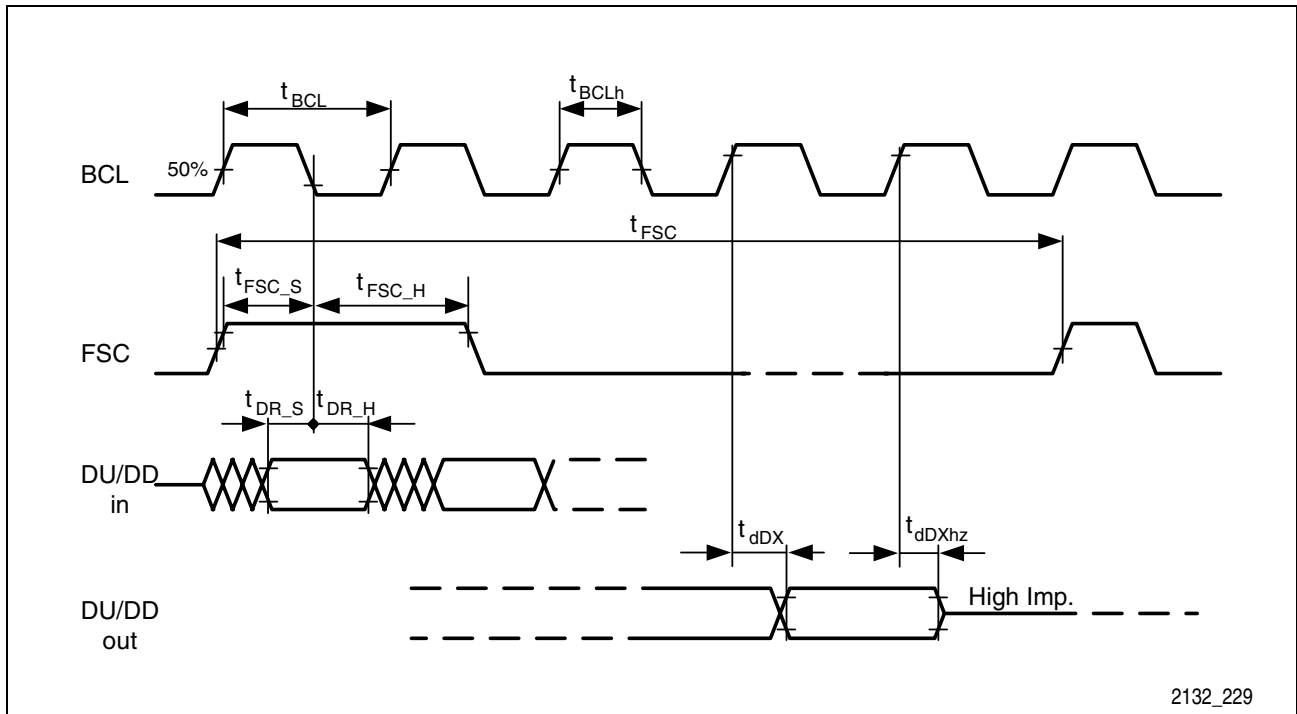

2132_229

Figure 26 PCM Interface Timing in Single Clocking Mode

Parameter	Symbol	Limit Values			Unit
		min.	typ.	max.	
Period of BCL	t_{BCL}		1/768000		μs
BCL high time	t_{BCLh}	$0.4 \cdot t_{BCL}$	$t_{BCL}/2$	$0.6 \cdot t_{BCL}$	μs
Period FSC	t_{FSC}		125		μs
FSC setup time	t_{FSC_s}	10	50		ns
FSC hold time	t_{FSC_h}	40	50		ns
DU/DD setup time	t_{DR_s}	10	50		ns
DU/DD hold time	t_{DR_h}	10	50		ns
DU/DD delay time ¹⁾	t_{dDX}	25		$t_{dDX_{min}} + t_{C_{Load}}$	ns
DU/DD delay time to high Z	t_{dDXhz}	25		50	ns

¹⁾ All delay times are made up by two components: an intrinsic time (min-time), caused by internal processing, and a second component $t_{C_{Load}} = 0.4\text{ns} \cdot C_{Load}/\text{pF}$, caused by external circuitry (C-load).

Electrical Characteristics and Timing Diagrams

8.6.2 Double Clocking Mode

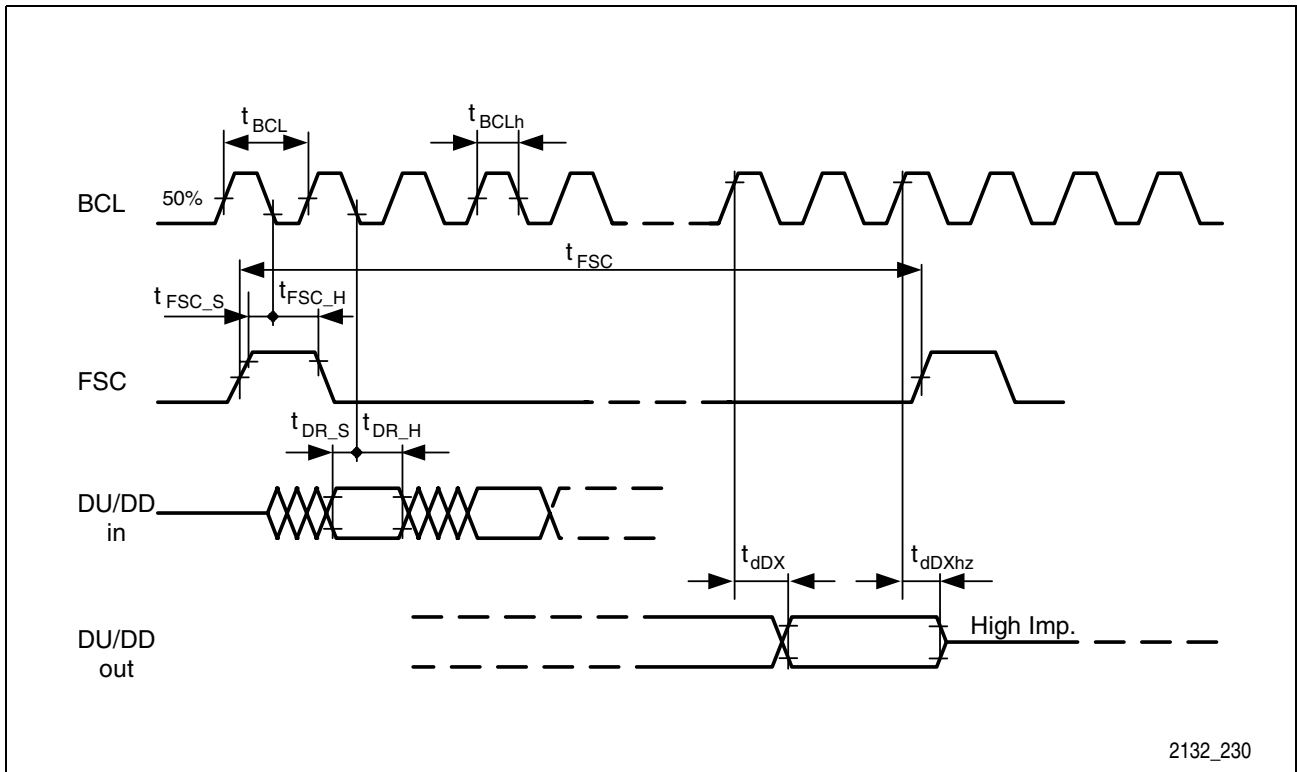

2132_230

Figure 27 PCM Interface Timing in Double Clocking Mode

Parameter	Symbol	Limit Values			Unit
		min.	typ.	max.	
Period of BCL	t_{BCL}		1/1536000		μ s
BCL high time	t_{BCLh}	$0.4 \cdot t_{BCL}$	$t_{BCL}/2$	$0.6 \cdot t_{BCL}$	μ s
Period FSC	t_{FSC}		125		μ s
FSC setup time	t_{FSC_s}	10	50		ns
FSC hold time	t_{FSC_h}	40	50		ns
DU/DD setup time	t_{DR_s}	10	50		ns
DU/DD hold time	t_{DR_h}	10	50		ns
DU/DD delay time ¹⁾	t_{dDX}	25		$t_{dDX_{min}} + t_{C_{Load}}$	ns
DU/DD delay time to high Z	t_{dDXhz}	25		50	ns

¹⁾ All delay times are made up by two components: an intrinsic time (min-time), caused by internal processing, and a second component $t_{C_{Load}} = 0.4ns \cdot C_{Load}/pF$, caused by external circuitry (C-load).

Electrical Characteristics and Timing Diagrams

8.7 Microcontroller Interface Timing

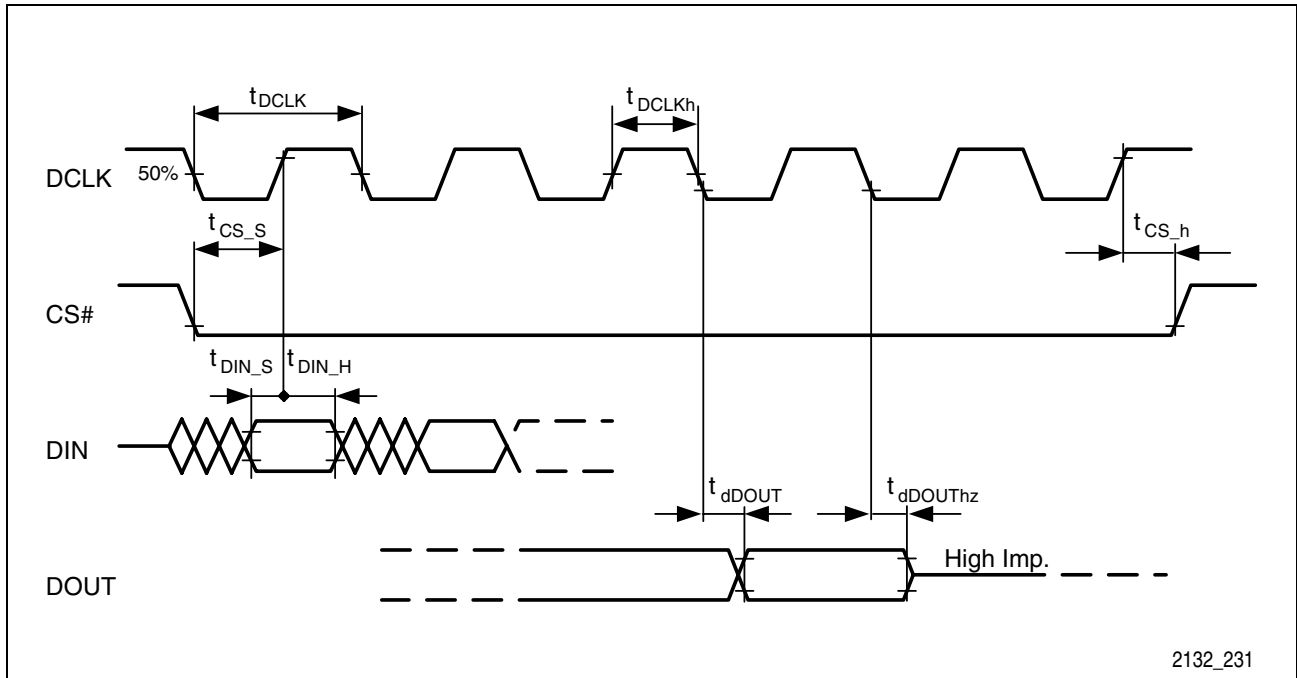

2132_231

Figure 28 Timing of the Microcontroller Interface

Parameter	Symbol	Limit Values			Unit
		min.	typ.	max.	
Period of DCLK	t_{DCLK}	1/8192			ms
DCLK high time	t_{DCLKh}	$0.4 * t_{DCLK}$	$t_{DCLK}/2$	$0.6 * t_{DCLK}$	μ s
CS# setup time	t_{CS_s}	10	50		ns
CS# hold time	t_{CS_h}	30	50		ns
DIN setup time	t_{DIN_s}	10	50		ns
DIN hold time	t_{DIN_h}	10	50		ns
DOUT delay time ¹⁾	t_{dDOUT}	30		$t_{dDOUT_min} + t_{C_Load}$	ns
DOUT delay time to high Z	$t_{dDOUThz}$	30		50	ns

¹⁾ All delay times are made up by two components: an intrinsic time (min-time), caused by internal processing, and a second component $t_{C_Load} = 0.4ns * C_{Load}/pF$, caused by external circuitry (C-load).

Electrical Characteristics and Timing Diagrams

8.8 Signaling Interface Timing

8.8.1 Timing from the Microcontroller Interface to the SO/SB-pins

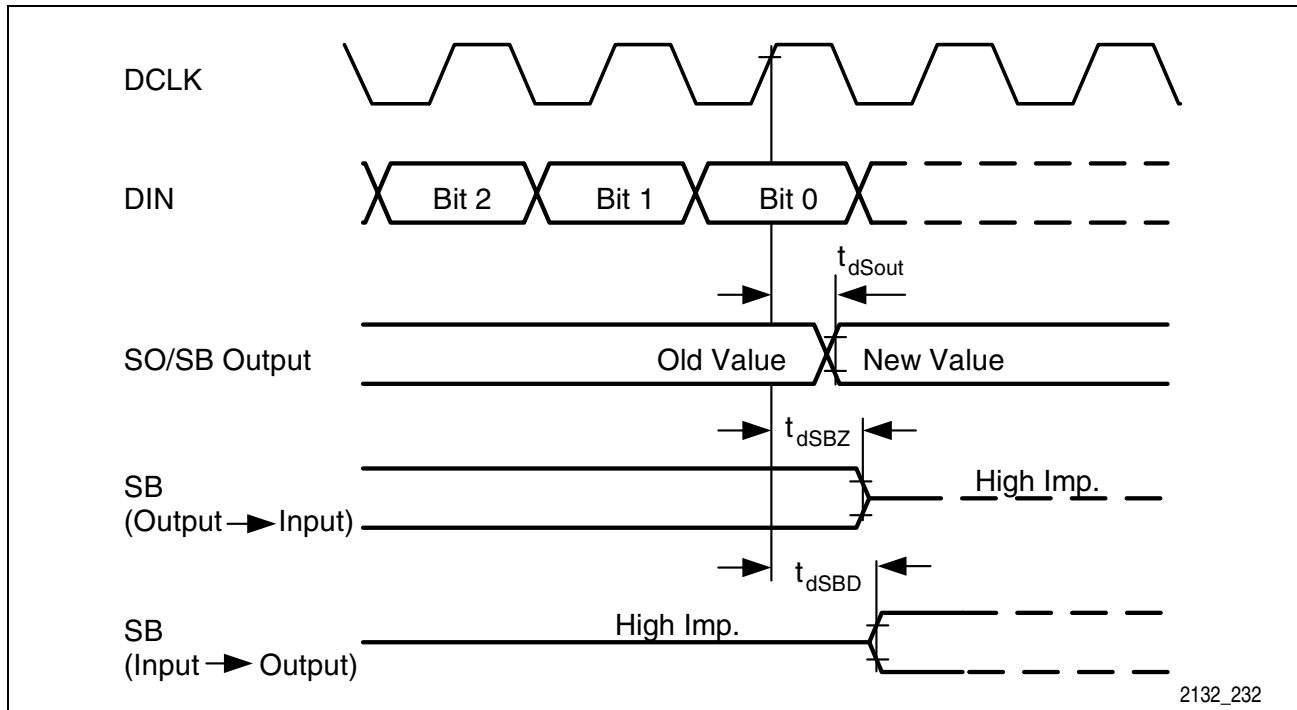

Figure 29 Signaling Output Timing (Data Downstream)

Parameter	Symbol	Limit Values			Unit
		min.	typ.	max.	
SO/SB delay time ¹⁾	t_{dSout}	30		$t_{dSout_min} + t_{C_Load}$	ns
SB to "Z" - time	t_{dSBZ}	40		100	ns
SB to "drive"-time	t_{dSBD}	40		$t_{dSBD_min} + t_{C_Load}$	ns

¹⁾ All delay times are made up by two components: an intrinsic time (min-time), caused by internal processing, and a second component $t_{C_Load} = 0.4ns \cdot C_{Load}/pF$, caused by external circuitry (C-load).

8.8.2 Timing from the SI/SB-pins to the Microcontroller Interface

The register update and interrupt behavior resulting from signaling input changes (data upstream – pins SI and SB, if programmed as signaling inputs) depend on internal sampling clocks, counters and register settings. No external reference signal is available. See Chapter 5.3.2 for a functional description.

9 Test Modes

Each SICOFI[®]2-TE channel has four test loops that feed the analog input signal back to the analog output (analog test loops), and five test loops that feed the PCM input signal back to the PCM output (digital test loops)..

Note: The signal path can also be cut off at two different points per receive and transmit direction.

9.1 Analog Loops

The four analog loops feed signals from the transmit path back into the receive path. **Figure 30** shows the locations of the analog loops.

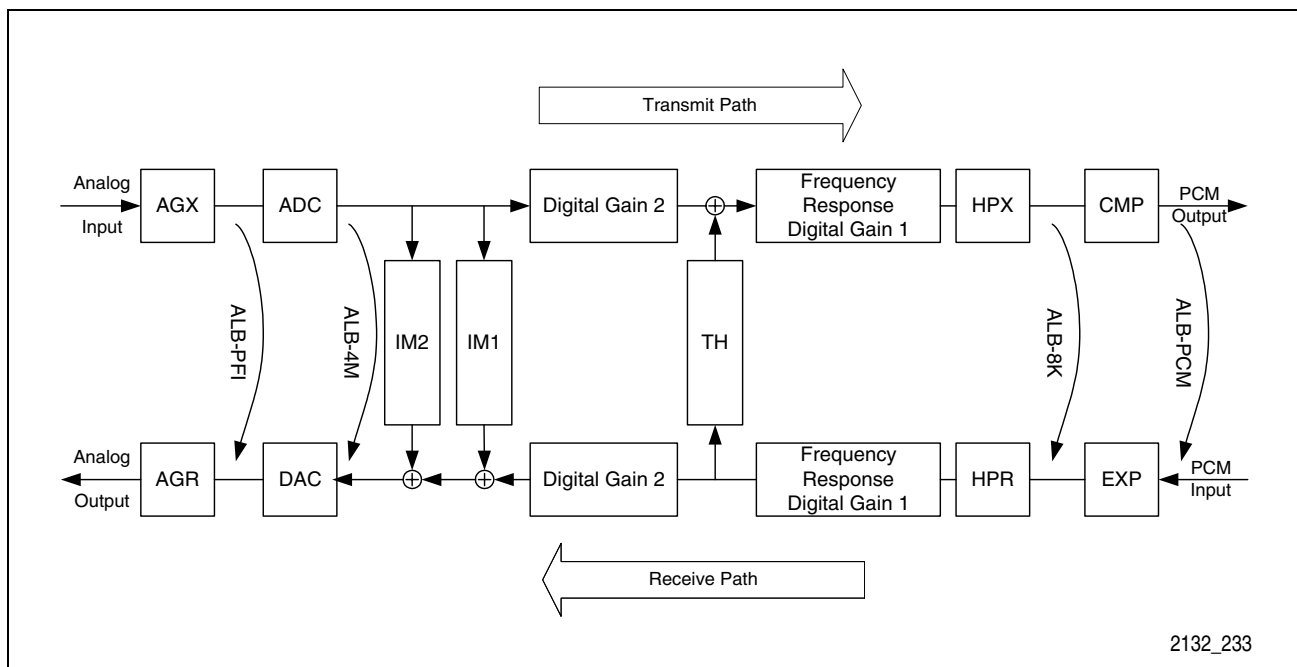

Figure 30 Analog Loops

Table 35 Analog Loop Programming in Register CR3, Bits 7 to 4

Test-Loops	Analog Loops (CR3.7 = 0)	
0000	All loops are disabled (normal operation).	
0001	ALB-PFI	Analog Loop Back via PREFI-POFI is selected.
0011	ALB-4M	Analog Loop Back via 4 MHz is selected.
0100	ALB-PCM	Analog Loop Back via 8 kHz (PCM) is selected and in all channels active. <i>(required slope setting in XR6.6, XR6.5 = 00 or 11).</i>
0101	ALB-8K	Analog Loop Back via 8 kHz (linear) is selected.

9.2 Digital Loops

The digital loops feed signals from the receive path back to the transmit path. There are five digital loops, which are shown in **Figure 31**.

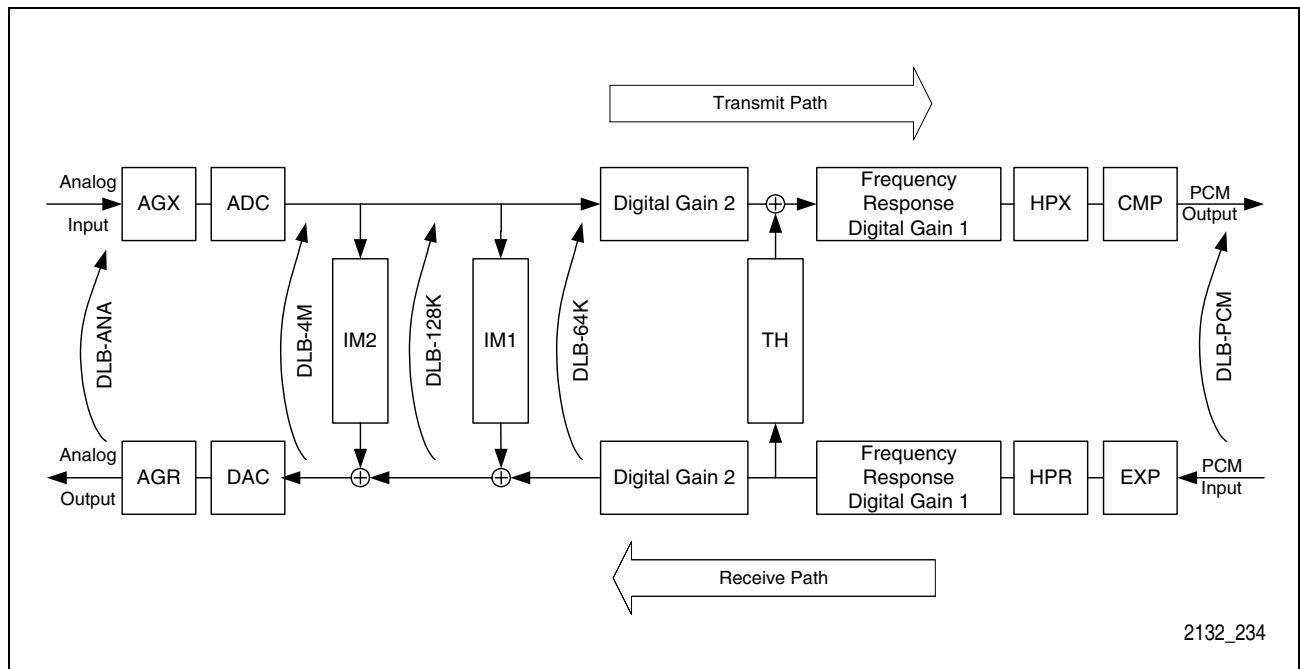

Figure 31 Digital Loops

Table 36 Digital Loop Programming in Register CR3, Bits 7 to 4

Test-Loops	Digital Loops (CR3.7 = 1)
1000	DLB-ANA Digital Loop Back via analog port is selected.
1001	DLB-4M Digital Loop Back via 4 MHz is selected.
1100	DLB-128K Digital Loop Back via 128 kHz is selected.
1101	DLB-64K Digital Loop Back via 64 kHz is selected.
1111	DLB-PCM Digital Loop Back via PCM Registers is selected.

9.3 Cut-Off's

The transmit path and the receive path can be cut off at two locations each. **Figure 32** shows the locations in the signal paths.

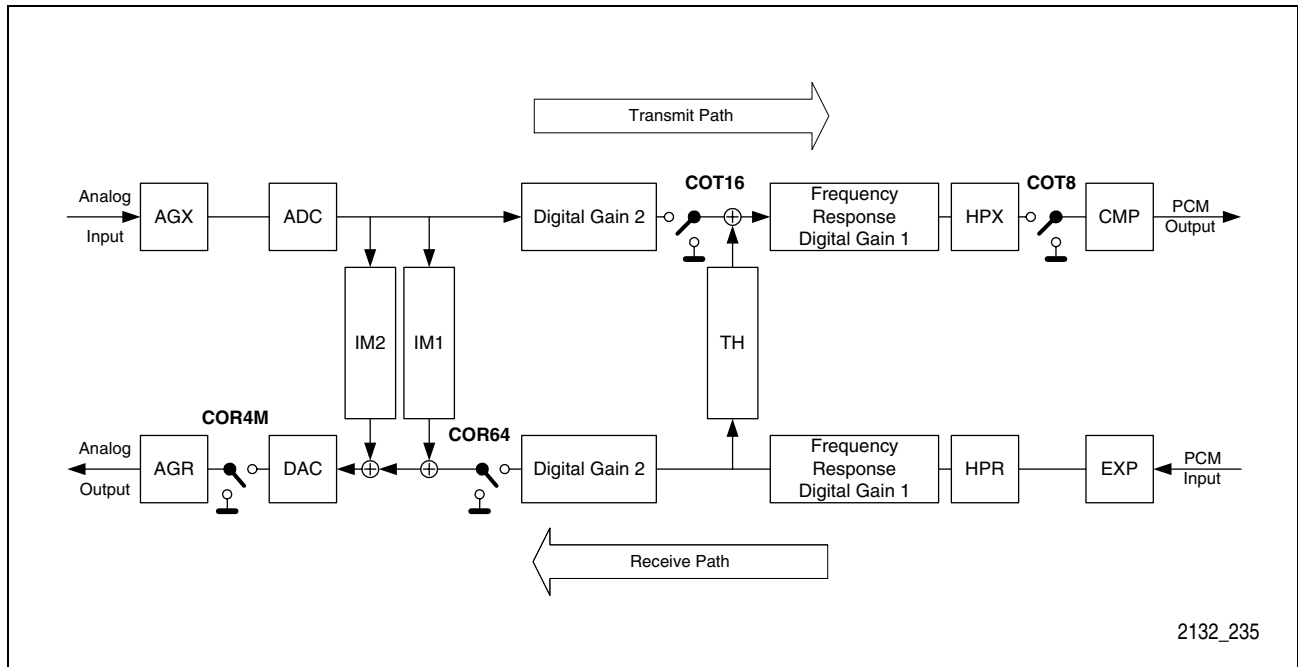

Figure 32 Cut-Off's

Table 37 Cut-Off Programming in Register CR2, Bits 7 to 5.

COT/R	Cut-Off's in the Transmit and the Receive Paths
000	All Cut-offs disabled (Normal Operation).
001	COT16 Cut Off Transmit path at 16 kHz (input of TH-Filter).
010	COT8 Cut Off Transmit path at 8 kHz (shortens the input of the compressor unit to ground, resulting in PCM idle codes in the transmit time slot).
101	COR4M Cut Off Receive path at 4 MHz (POFI-output).
110	COR64 Cut Off Receive path at 64 kHz (IM-filter input).

10 Package Outlines

P-MQFP-64 (Plastic Metric Quad Flat Package)

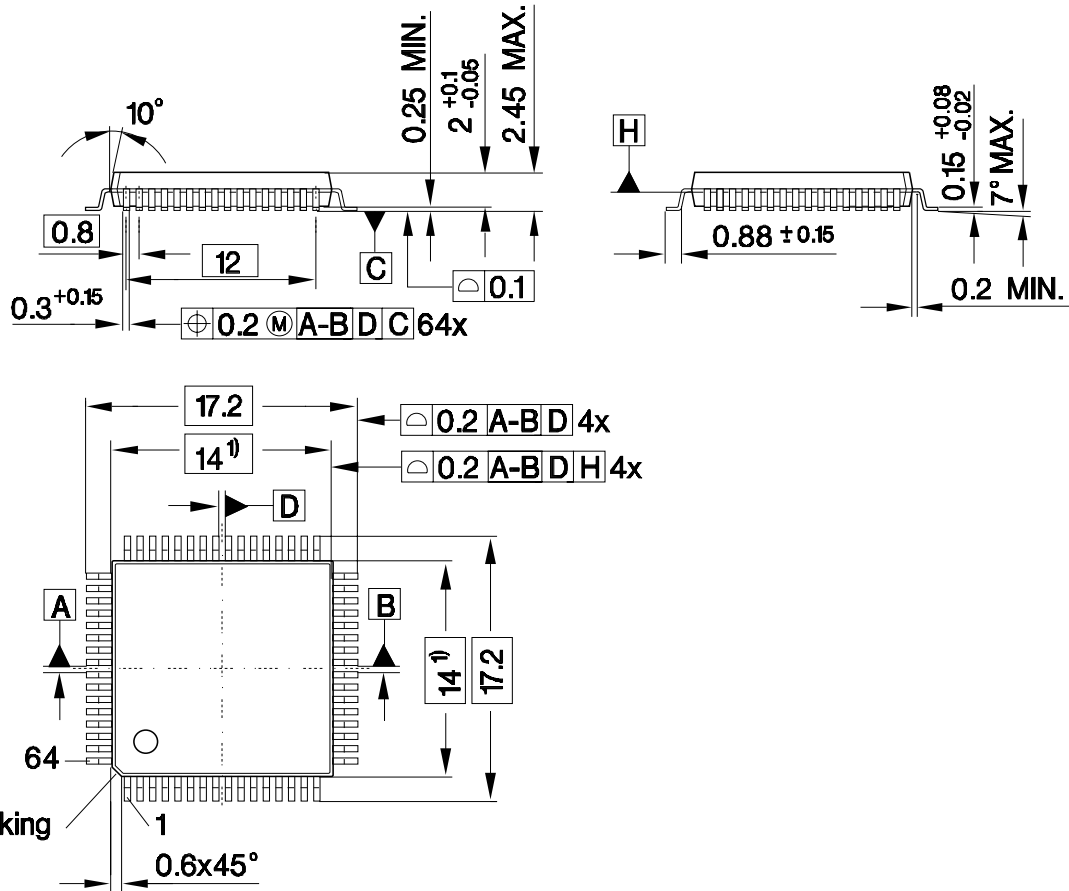

1) Does not include plastic or metal protrusion of 0.25 max. per side

GPM05250

Sorts of Packing

Package outlines for tubes, trays etc. are contained in our Data Book "Package Information".

SMD = Surface Mounted Device

Dimensions in mm

11 Glossary

AC	A lternating C urrent
ADC	A nalog-to- D igital C onverter
CMOS	C omplementary M etal O xide S emiconductor
CRAM	C oefficient R AM
DAC	D igital-to- A nalog C onverter
DC	D irect C urrent
DLC	D igital L oop C arrier
DSP	D igital S ignal P rocessor
DTMF	D ual T one M ulti F requency
FIR	F inite I mpulse R esponse
FTTC	F iber- T o- T he- C urb
IIR	I nfinite I mpulse R esponse
IOM-2	I SDN- O riented M odular 2 nd G eneration
ISDN	I ntegrated S ervices D igital N etwork
ITU	I nternational T elecommunication U nion
ITU-T	I nternational T elecommunication U nion- T elecommunication Standardization Sector (formerly CCITT)
NT	N etwork T ermination
PBX	P rivate B ranch E xchange
PCM	P ulse C ode M odulation
POTS	P lain O ld T elephone S ystem
PSTN	P ublic S witched T elephone N etwork
PTT	P ost T elephone T elegraph
QSICOS	Q uad S ICOFI C oefficient S oftware
RITL	R adio- I n- T he- L oop
RT	R emote T erminal
SICOFI	S ignal P rocessor C odec F ilter
SLIC	S ubscriber L ine I nterface C ircuit
t/r	tip/ring
TA	T erminal A dapter

Index

Symbols

μ-Law 2, 11, 14, 19, 27
 μ-Law mode 15, 21

Numerics

0 dBm0-Levels 14
 8-bit time slots. 2

A

A/μ-Law compression/expansion 3
 A/D and D/A converters . . . 11, 14, 18, 22, 24
 Absolute gain 17
 Absolute group delay 18
 Absolute maximum ratings 42
 AC transmission characteristics 25
 Accuracy of digital filters. 10, 11
 ADC 2, 3, 11
 A-Law 2, 11, 14, 19, 27
 A-Law mode 15
 Ambient temperature 42
 Analog ground pins. 8, 9, 27
 Analog I/O. 2
 Analog input 13
 Analog input/output pins 27
 Analog Interface 14, 44
 Analog interface 3, 25, 26, 44
 Analog Interface pins 27
 Analog loop programming. 49
 Analog loops. 3, 49
 Analog output 13
 Analog supply 41
 Analog supply reference voltage 9
 Analog supply voltage. 8
 Analog voice input/output 8
 Analog voltage levels 14
 Application hints 39
 Application Notes 1
 AR. 37

Architecture 2
 Attenuation 18
 AX 37

B

Balancing filter. 24
 Bi-directional signaling pins. 8, 30
 Bit clock input (BCL) 27, 28
 Blocking capacitors 40
 Board design 40
 Board layout 41
 Byte-by-byte transfer 33

C

Ceramic capacitors 40
 Channel operating ranges 43
 Channel-pair 31
 Channels 2, 21, 27, 35
 Channel-specific coefficients. 37
 Channel-specific registers. . . . 11, 12, 35, 36
 Chip select. 6, 31, 32
 Chopper clock 6
 Clock 29, 31
 Clock input. 11
 Clock output signals 2, 31
 Clock programming 31
 Codec filter 2
 Coefficient calculation & configuration software 3
 Coefficient Operation (COP) command . . . 38
 Coefficient operation commands. 37
 Coefficient RAM. 11, 31, 32, 35, 37
 Command sequences 34, 38
 Command type 38
 Commands 32
 Common configuration registers . . . 11, 35, 36
 Compression 3
 Compressor 11
 Configuration of interfaces. 25
 Configuration registers 33, 35

Control data input/output pins	32	Digital loops	3, 50
Conversion utilities	39	Digital output	13
COP	38	Digital supply voltage.	7
COP command sequences.	37	Digital, programmable filters	10
Coupling capacitors	25, 27, 44	DIN	47
CR0 to CR5	35	Double clocking mode.	7
CR0 to CR7	36	Double clocking mode timing.	46
CRAM.	11, 31, 33, 35, 37, 38	DOUT	47
CRAM structure	37	Driving capability	3, 25
Crosstalk.	21	DSP core.	2, 3, 10, 11
CR-Registers	11	DTMF.	3
CS#.	31, 47	Dynamic gain.	3
Cut-Off programming	51	Dynamic range	11
Cut-Off's	51		
D		E	
D/A and A/D converters	18, 22, 24	EASY 2466	39
DAC	2, 3, 11	EASY 2466 evaluation system	39
Data bytes.	32, 33	Echo	24
Data Clock	6	Electrical characteristics	42
Data clock.	32	Evaluation boards	39
Data downstream input (DD)	28	EVC50x	39
Data downstream output (DD)	28	Expander	11
Data input pins	6	Expansion	3
Data output pins	6	Extended Operation (XOP) command	38
Data pins.	31	External amplifier.	25
Data rate.	7	External components.	24
Data rates	27		
Data upstream input (DU).	28	F	
Data upstream output (DU).	28	Filter capacitors	40
DCL master clock input.	28	Filter characteristics.	10
DCLK	47	Filter coefficients	25
Debouncing functions	29, 31	Filter coefficients storage.	11
Decimation	11	Filter structures	11
Detect specific tones.	10	Flow diagram.	16
Development boards.	3, 39	Fluctuation.	10
Digital filters	3	Frame delay.	27
Digital ground pins	6	Frame synchronization clock.	7, 28
Digital input.	13	Frequency correction.	11
Digital interface.	43	Frequency response	3, 18, 25
Digital loop programming	50	Frequency response corrections.	10, 16

FRR	37	Interfaces	35
FRX	37	Intermodulation	20
FSC	45, 46	Intermodulation distortion	20
Functional blocks	35	Internal registers	31
G		Interpolation	11
Gain	15, 24	Interrupt generation	31
Gain accuracy	17	Interrupt output	29
Gain deviations with input level	17	Interrupt output pins	30, 31
Gain tracking	17	Interrupt pins	29
Ground pins	41	Interrupts	8
Ground plane	41	Inventory costs	4
Ground-key detection	10	IOM-2 bit clock	7
Group delay	18, 24	IOM-2 data downstream (DD)	7
Group delay absolute values	18	IOM-2 data upstream (DU)	7
Group delay distortion	19	IOM-2 frame	18, 27
H		IOM-2 PCM interface	2, 3, 11, 14, 25, 27
Hardware filters	11, 22	IOM-2 PCM interface timing	45
Hardware reset	13	ITU-T	3, 14
Harmonic distortion	20	L	
High impedance state	32	Level adjustments	10, 11
HW-Reset	12	Level metering	3, 10
I		Line characterization	10
I/O pins	29	Linearity	3, 11
Identification byte	33	Load capacities	14
Idle channel noise	19	Local requirements	10
IM filter	24, 37	Loop filters	10
Impedance matching	3, 10, 11, 16	M	
Independent filter structures	2	Manufacturing test	3
Input impedance	10, 27, 44	Master clock input (DCL)	7
Input leakage current	43, 44	Maximum signal levels	14
Input offset voltage	44	Measurements	39
Input pins	12, 29	Microcontroller	10
Input resistance	25, 44	Microcontroller interface	10, 31, 37, 38
Input voltage range (AC)	44	Microcontroller interface timing	47
Input voltages	43	Microcontrollers	25
INT12	31	N	
Interface description	25	Noise	19

Noise rejection	40	Power On.	12
Non usable input.	6	Power spectral density	23
Non usable input/output	6	Power supply rejection ratio	43
Not connected pins.	6, 9	Power-saving state	12
O		POWER-UP state	31
On-/off-hook detection	10	Product Brief	1
Operating conditions.	16	Product Overview	1
Operating range	43	Programmable debouncing	3
Operating state	12, 13	Programmable digital filters	3
Operation of interfaces	25	Programmable filters	24
Operational description.	12	Programmable frequency	13
Optimization	39	Programmable tone generators.	3
Out-of-band discrimination	22, 23	Programmer's Reference Manual	1
Out-of-band idle channel noise.	23	Programming overview	35
Out-of-band signals	22, 23, 25	PSB 2134	1
Output load	44	Psophometric.	19
Output offset voltage.	44	Q	
Output resistance	44	QSICOS.	3, 39
Output voltages.	43	R	
Overload compression	21	Read access	33, 36
Overload point	14, 21, 25	Read commands	33, 34
Oversampling	11	Receive delay	18
P		Receive path	10, 49, 50, 51
Package	3	Reference voltage pin	9, 27
Package Outlines	52	Register maps	36
PCM data format.	27	Register model	35
PCM Interface pins	28	Register values	13
PCM interface timing	46	Registers	11
Peak amplitude.	14, 25	Reset.	7
PEB 2266	1	Reset state	12, 13, 44
PEB 2466	1	Reset timing.	44
Pin configuration.	5	RESET#.	12, 13
Pin definitions and functions.	6	RESET# pin.	44
Pin descriptions	5	Resolution	11
Pin diagram.	5	Return loss	10
PLL	11	Ring generator output	8
Power dissipation	12, 14	Ring signals.	10
Power dissipation (package).	42	Ringing signal (RGEN)	2

RST.	12	Status Operation (SOP) command ...	38
S		Storage temperature	42
Sampling	32	STUT 2466	3, 39
Sampling intervals	31	STUT 5502	39
Sampling slopes	27	Subscriber line interface circuits ...	2, 10, 25
Schmitt-Trigger input	44	Subscriber lines	29
Serial input	13	Supervision and signaling functions ..	29
Serial Interface	2	Supply current	43
Serial Microcontroller Interface	31	Supply voltage	3
Serial microcontroller interface ...	10, 25	Supply voltage pins	27
Sigma-delta	11	Support tools	3, 39
Signal levels	3, 15	SW-Reset	12
Signal paths	51	System diagnostics	3
Signal processor	10	System tests	3
Signal rejection	22	T	
Signaling example	30	Tantalum capacitors	40
Signaling input pins	8, 30	Telco specification	25
Signaling interface	10, 25, 29	Telephone interface	10
Signaling Interface pins	30	Telephone line	25
Signaling interface timing	48	Teletax filters	25
Signaling output pins	8, 30	Teletax pulses	22, 25
Signaling output timing	48	Test circuit	40
Signaling pins	2, 29	Test loops	24, 49
Signaling registers	31	Test modes	49
Signaling status changes	29	Test relays	10
Signal-to-noise performance	11	TG1 and TG2	37
Signal-to-total distortion ratio	20	TH-filter	35, 37
Sine wave signal	14	Three-Wire access	34
Single clocking mode	7	Time slot	2, 11
Single clocking mode timing	45	Time to market	4
Single frequency distortion	21	Timing	45, 47, 48
SLIC	2, 3, 10, 24, 25	Timing diagrams	42
SLIC daughter cards	39	Tip/ring	10, 25
SLIC interfaces	30	Tone generators	3, 10
SOP	38	Tool package	39
Spikes	44	Total distortion receive/transmit.	20
Standby	43	Total gain calculation	15
Standby state	12, 13	Transfer functions	25
State diagram	12	Transformer	3, 10, 25
States	12, 13	Transformer SLIC	25

Transhybrid balancing	3, 10, 11, 16, 24
Transhybrid loss	24
Transmission characteristics	10, 14, 35
Transmission system	39
Transmit delay	18
Transmit path	10, 49, 50, 51
Types of commands	38

V

VIN-pins	25
Voice channels	11
Voltage levels	13
VOUT-pins	25

W

Waiting time	33
Website.	1
Write access	32, 36
Write commands.	32, 34

X

XOP	38
XR0 to XR7.	36
XR-Registers	11

Infineon goes for Business Excellence

“Business excellence means intelligent approaches and clearly defined processes, which are both constantly under review and ultimately lead to good operating results.

Better operating results and business excellence mean less idleness and wastefulness for all of us, more professional success, more accurate information, a better overview and, thereby, less frustration and more satisfaction.”

Dr. Ulrich Schumacher

<http://www.infineon.com>

Published by Infineon Technologies AG